

P/N A3A565FB

SALES KIT, MACRO, PROGRAMMABLE, 4 BUTTON INCLUDING:

- 1 EA A3A565CB Transmitter
- 1 EA A3A564A Receiver

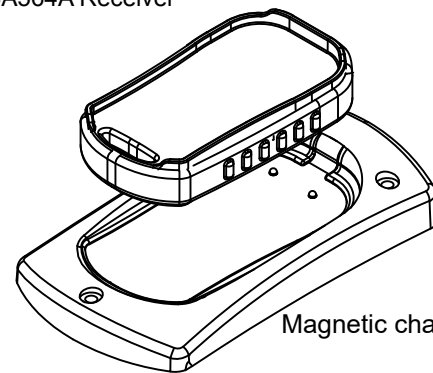

Magnetic charger pad

Only use approved chargers
 MACRO CHARGER PAD/ 110-240VAC (B20203A)
 MACRO CAR CHARGER PAD/ 12-24VDC (B20202A)

This device complies with Part 15 of the FCC Rules. Operation is subject to the following two conditions: (1) this device may not cause harmful interference, and (2) this device must accept any interference received, including interference that may cause undesired operation. Changes or modifications not expressly approved by Kar-Tech will void the user's authority to operate the equipment.

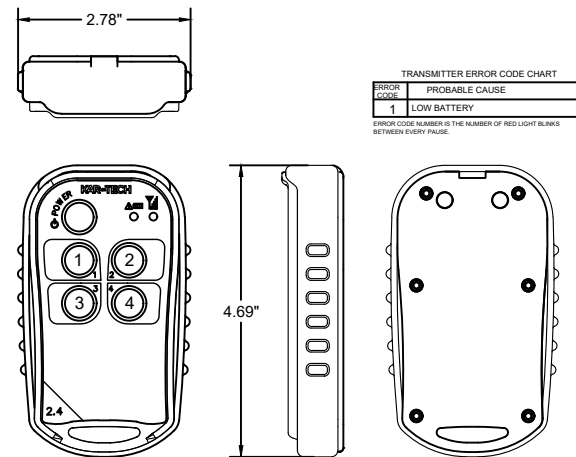

P/N A3A565CB
 TRANSMITTER, MACRO, 4 BUTTON

ERROR CODE	PROBABLE CAUSE
1	LOW BATTERY

ERROR CODE NUMBER IS THE NUMBER OF RED LIGHT BLINKS BETWEEN EVERY PULSE

ERROR CODE	PROBABLE CAUSE
1	RF COMMUNICATION PROBLEM
2	LOW BATTERY

ERROR CODE NUMBER IS THE NUMBER OF RED LIGHT BLINKS BETWEEN EVERY PULSE

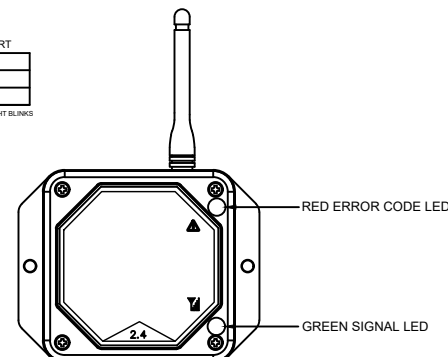
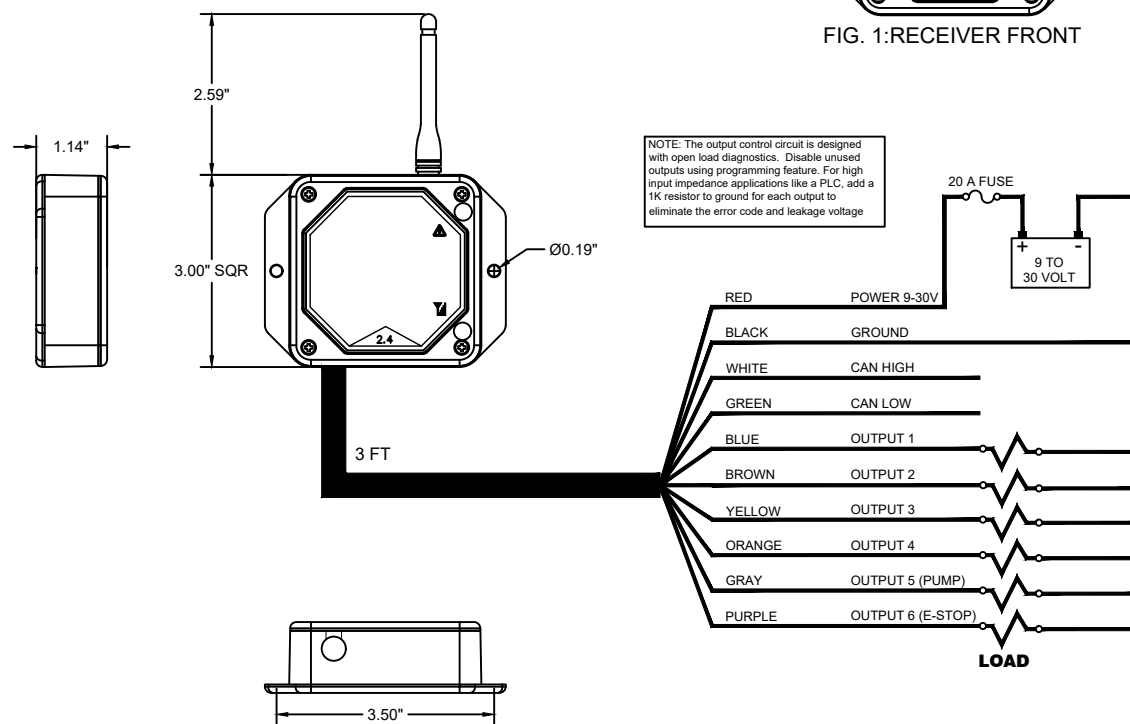

FIG. 1: RECEIVER FRONT



P/N A3A5645A
 RECEIVER, 6 OUTPUT, PROGRAMMABLE

OPERATION

- To turn on the transmitter, press and hold the POWER button for at least 2 seconds and release
- To turn the transmitter off, press and hold the POWER button until the LEDs turn off
- The transmitter is designed with a power saving feature which turns the transmitter off after 15 minutes if no buttons are pressed.
- There are red and green LEDs both on the keypad of the transmitter and inside the receiver case. The green LED will blink rapidly when the transmitter and receiver are communicating. It will blink slowly if there is no communication (i.e. - no power to the receiver)
- The red LED on the receiver will blink if there is a shorted or open output. Refer to the ERROR CODE CHART tables and count the number of blinks to determine the output with the fault (NOTE: the receivers with CAN do not have output error codes).
- The transmitter's red LED blinks 1 time per second if the battery is low and needs to be charged.
- The red LED will stay on while charging and when the charge is completed the green LED will stay on.
- It will take longer to charge if the transmitter is on during charging.

SYNCHRONIZING TRANSMITTER AND RECEIVER

- Each transmitter and receiver pair is synchronized together at the factory. If a new transmitter is needed, synchronizing is required. Use the following procedure:
- Make sure both the transmitter and receiver are off.
 - Press and hold the POWER button on the transmitter for more than 10 seconds. The red and green LED will start to blink.
 - Apply power to the receiver
 - Wait for a few seconds until only the green LED begins to blink on the transmitter
 - Teach complete

PROGRAMMING

The user can determine output functionality (momentary or maintained action) and program the system to respond as desired. This is determined by the following procedure:

- Turn the receiver off. Turn the transmitter on (press and hold POWER until both LEDs turn on, then release)
- Press and hold 1, 3, and 4 and release. Red LED should be blinking on the transmitter
- Turn the receiver on, make sure green LED is blinking before proceeding to the next step. Be sure all outputs are connected to a load and that there are no error codes present (NOTE: outputs may cycle on and off while programming)
- Are any outputs to be latched (push on/push off)? If yes continue. If no, skip to step 9 for outputs to be momentary.
- Press button 1-4 corresponding to output 1-4 that is to be latched, until green LED goes on, then off
- Press button that corresponds to OFF until green LED goes on, then off. This can be the same button that turns the output on. In this case, pressing the button alternates the output between ON and OFF.
- If latched output should turn OFF for transmitter out of range condition press the button defined in step 6. If latched output should stay ON for transmitter out of range condition press any button other than button defined in step 6.
- Repeat steps 5, 6, and 7 for any more outputs that are to be latched
- Press POWER briefly. The receiver's red LED should blink, indicating that this step is accepted and complete. The red LED on the transmitter should also start to blink at a different rate.
- Are any outputs to be disabled (no output and no error code)? If yes, continue, if no, skip to step 12
- One at a time, press and hold each button 1-4 corresponding to output 1-4 that is to be disabled, until the green LED goes on, then off
- Press POWER briefly. The receiver's red LED should blink, indicating that this step is accepted and complete. The red LED on the transmitter should also start to blink at a different rate.
- Is it desired to use the pump functionality (see description below)? If yes, continue, if no, skip to step 15
- One at a time, press and hold each button 1-4 corresponding to output 1-4 that is to be associated with the pump output, until the green LED goes on, then off
- Press POWER briefly. The receiver's red LED should blink, indicating that this step is accepted and complete. The red LED on the transmitter should also start to blink at a different rate.
- Is it desired to use the e-stop functionality (see description below)? If yes, continue, if no, skip to step 18
- To engage the e-stop functionality, press button 2 until the green LED goes on, then off
- If no error code is desired for the E-STOP output press button 3 to disable otherwise go to step 19 to keep error code enabled
- If the E-STOP output should turn OFF for transmitter out of range condition press button 4 otherwise go to step 20 to keep the output ON for transmitter out of range condition
- If no error code is desired for the PUMP output press button 1 to disable otherwise go to step 21 to keep error code enabled
- Press POWER briefly. The receiver's red LED should blink, indicating that this step is accepted and complete.
- One at a time, press and hold each button 1-4 that the corresponding output error code needs to be disabled, until the green LED goes on, then off
- Press POWER briefly. The receiver's red LED should blink, indicating that this step is accepted and complete.
- Programming complete

NOTES:

- Pump functionality: output 5 will turn on with any outputs that have been associated with it
- E-stop functionality: output 6 will be on as long as the transmitter is on. If the transmitter is turned off or POWER is pressed output 6 will go off along with all latched outputs. To reset, turn the transmitter back on or re-cycle power to the receiver and re-engage the outputs as before
- If the receiver does not blink the red LED after each sequence or the transmitter's red LED does not blink at a different rate as described above, the programming was not accepted for that section. Start from the beginning and go slowly. Keep a distance of 2-3 feet from the receiver when programming.
- The factory settings are: 4 momentary outputs, no pump output, and no e-stop output

SLEEP TIME

All transmitters have the ability to change the sleep time from the default to user's preference. The transmitter is factory set to turn off (sleep) after 15 minutes. To change the time the transmitter waits before going to sleep, use the following procedure:

- With the transmitter off, press and hold buttons 1, 2, 4, and POWER
- Keep holding the buttons for a few seconds then release the buttons. At this point, both lights will blink once per second
- On the transmitter, press one of the following buttons to adjust the sleep time:
 - 1=15 minutes
 - 2=30 minutes
 - 3=1 hour
 - 4=sleep disabled
- Sleep time programming complete

CLONING TRANSMITTERS

WARNING! - ONLY ONE TRANSMITTER CAN BE ON AT A TIME, THEY CANNOT BE USED SIMULTANEOUSLY - use with CAUTION!

Occasionally, it is desirable to have more than one transmitter work with a single receiver. This is accomplished by a process called cloning. Cloning allows an additional transmitter (B) to have the same ID code as the original transmitter (A). If this feature is desired, use the following procedure:

- Make sure both transmitters and the receiver are off
- On Transmitter A, press and hold the POWER button for 10 seconds until LEDs blink, then release. Green and red LEDs will blink together at this point
- On Transmitter B, press and hold buttons 1, 2, and POWER simultaneously until both LEDs start to blink
- Wait for few seconds until the green LED starts to blink on both transmitter A and transmitter B.
- Turn both the transmitters off
- Synchronize one of the transmitters to the receiver using SYNCHRONIZING TRANSMITTER AND RECEIVER instructions above

If the cloning feature has been invoked and is no longer desired, the ID code of one of the transmitters needs to be changed. This will unclone the transmitters. If this is desired, use the following procedure:

- Make sure the receiver and transmitter are OFF
- Press and hold buttons 2, 3, 4 and POWER buttons simultaneously for 5 seconds until both LEDs start toggling then release
- Press any button again to select a new ID
- Uncloning complete
- Follow the SYNCHRONIZING TRANSMITTER AND RECEIVER procedure above to link the uncloned transmitter to a new receiver

SPECIFICATIONS:

- Electrical:
- RF Transmit power (EIRP): 100 Mw
 - RF Frequency: 2.4GHz
 - Transmitter:
 - Power: Rechargeable 3.7V Lithium Polymer battery
 - Operation time with full charge: 30 to 40 hours continuous
 - Receiver:
 - Power: 9 to 30 Volts DC
 - Outputs: 5A max each (20A system max)
- Environmental:
- Transmitter: -20°C to +60°C
 - Receiver: -40°C to +85°C

CAD DRAWING DO NOT REUSE MANUALLY					
SCALE	DRAWN	DATE	CHECKED	APPROVED	DRAWING NO.
FULL	JC	03-06-24			3A-565-F-B-3A

CAN PACKET 1 FROM RECEIVER TO CONTROLLER								
PGN	FF00			SRC ADDR	7			
PGN PRIORITY	6			PACKET ID	0x18FF0007			
TIMING	100 ms							
	DATA 0	DATA 1	DATA 2	DATA 3	DATA 4	DATA 5	DATA 6	DATA 7
BIT 1	0-1 TOGGLE	-	BUTTON 1	POWER BUTTON	-	-	-	-
BIT 2	RF LINK	-	BUTTON 2	-	-	-	-	-
BIT 3	-	-	BUTTON 3	-	-	-	-	-
BIT 4	-	-	BUTTON 4	-	-	-	-	-
BIT 5	-	-	BUTTON 5	-	-	-	-	-
BIT 6	-	-	BUTTON 6	-	-	-	-	-
BIT 7	-	-	BUTTON 7	-	-	-	-	-
BIT 8	-	-	BUTTON 8	-	-	-	-	-
CAN PACKET 2 FROM RECEIVER TO CONTROLLER								
PGN	FF01			SRC ADDR	7			
PGN PRIORITY	6			PACKET ID	0x18FF0107			
TIMING	100 ms							
	DATA 0	DATA 1	DATA 2	DATA 3	DATA 4	DATA 5	DATA 6	DATA 7
BIT 1	OUTPUT 1	OUTPUT 9	-	-	-	-	-	-
BIT 2	OUTPUT 2	OUTPUT 10	-	-	-	-	-	-
BIT 3	OUTPUT 3	-	-	-	-	-	-	-
BIT 4	OUTPUT 4	-	-	-	-	-	-	-
BIT 5	OUTPUT 5	-	-	-	-	-	-	-
BIT 6	OUTPUT 6	-	-	-	-	-	-	-
BIT 7	OUTPUT 7	-	-	-	-	-	-	-
BIT 8	OUTPUT 8	-	-	-	-	-	-	-
CAN PACKET 3 FROM RECEIVER TO CONTROLLER								
PGN	FF02			SRC ADDR	7			
PGN PRIORITY	6			PACKET ID	0x18FF0207			
TIMING	500ms							
	DATA 0	DATA 1	DATA 2	DATA 3	DATA 4	DATA 5	DATA 6	DATA 7
BIT 1	BATTERY VOLTAGE 0.05V/BIT		LOW BATTERY	-	-	-	-	-
BIT 2			TX NOT IN NEUTRAL MODE	-	-	-	-	-
BIT 3			-	-	-	-	-	-
BIT 4			-	-	-	-	-	-
BIT 5			-	-	-	-	-	-
BIT 6			-	-	-	-	-	-
BIT 7			-	-	-	-	-	-
BIT 8			-	-	-	-	-	-
CAN PACKET 4 FROM CONTROLLER TO RECEIVER								
PGN	FF00			SRC ADDR	6			
PGN PRIORITY	6			PACKET ID	0x18FF0006			
TIMING	100ms							
	DATA 0	DATA 1	DATA 2	DATA 3	DATA 4	DATA 5	DATA 6	DATA 7
BIT 1	0	MESSAGE INDEX	CAN PGN	PRIORITY	SOURCE ADDRESS	PERIOD		
BIT 2								
BIT 3								
BIT 4								
BIT 5								
BIT 6								
BIT 7								
BIT 8								

CAN MESSAGING:

- The three packets below are sent from the receiver to the controller. Their indexes are as follows:
 Packet 1 message index = 0
 Packet 2 message index = 1
 Packet 3 message index = 2
- The fourth packet can be sent to the receiver to change the settings of the three packets above
- Details of each packet are below

PACKET 1:

- This packet toggles Bit 1 under DATA 0, reports the link status between the transmitter & receiver and the status of each of the transmitter's inputs
- Example:
 (Decimal) 2 0 5 0 0 0 0 0
 (HEX) 0x02 0 0x05 0x00 0x00 0x00 0x00 0
 This reports that the toggling bit is currently low, the transmitter & receiver are linked and that buttons 1 & 3 are pressed on the transmitter.

PACKET 2:

- This packet reports the status of each of the receiver's outputs (on or off).
- Example:
 (Decimal) 136 0 0 0 0 0 0 0
 (HEX) 0x88 0x00 0x00 0x00 0x00 0 0 0
 This reports that the following outputs are ON: output 4 and output 8.

PACKET 3:

- This packet reports the battery voltage applied to the receiver and any error codes if present. For battery voltage, byte 0 is the least significant byte and byte 1 is the most significant.
- Example:
 (Decimal) 22 1 2 0 0 0 0 0
 (HEX) 0x16 0x01 0x02 0x00 0x0 0 0 0
 This reports that the battery voltage is at 13.9V and the transmitter is not in neutral mode.

PACKET 4:

- This packet is used to configure Packets 1-3, if different settings are desired for PGN, priority, source address, and period.

-PGN: the address number of the device to communicate with on the bus. Byte 2 is the least significant byte and byte 3 is the most significant.

-Source Address: the address of the receiver.

-Priority: the importance for the packet

-Period: the time interval between packets sent on the bus. Byte 6 is the least significant byte and byte 7 is the most significant. Period should be entered in ms.

- Example:

(Decimal) 0 0 239 255 3 6 50 0
 (HEX) 0 0x00 0xEF 0xFF 0x03 0x06 0x32 0x00

This sets Packet 1's packet ID from 0x18FF0007 to 0x0CFFEF06 and changes the period to 50ms.

- To return all three packets to the default settings shown below, send the following:

(Decimal) 0 3 0 0 0 0 0 0
 (HEX) 0 0x03 0x00 0x00 0x00 0x00 0x00 0x00

SPECIFICATIONS:

- Baud Rate = 250K
- Make sure your CAN bus has the proper terminating resistors installed. These are two 150 ohm resistors across CAN HIGH and CAN LOW, on at either end of the CAN bus.