

## USER MANUAL



### Aquarius 2S

EN

DE

NL

FR

ES

Handheld remote /  
Receiver sticker

Set sticker

### English

#### Table of contents

- Introduction
- Safety
- Dimensions & weight
- Description
- Specifications
- Features
- Functions
- Safety Package
- System identification
- Pairing a handheld transmitter to the receiver
- Changing functions
- System assembly
- Range optimization
- Resolving problems
- Maintenance
- Service
- Disclaimer
- Declaration of conformity

### Deutsch

#### Inhaltsverzeichnis

- Einleitung
- Sicherheit
- Abmessungen und Gewicht
- Beschreibung
- Spezifikationen
- Eigenschaften
- Funktionen
- Sicherheitspaket
- System-Identifikation
- Koppeln eines Handsenders mit dem Empfänger.
- Ändern von Funktionen
- Montage des Systems
- Reichweiteoptimierung
- Behebung von Störungen
- Wartung
- Service
- Haftungsausschluss
- Konformitätserklärung

### Français

#### Table des matières

- Introduction
- Sécurité
- Dimensions et poids
- Description du produit
- Spécifications de l'appareil
- Caractéristiques
- Fonctions
- Paquet de sécurité
- Identification du système
- Appairage d'un émetteur portatif au récepteur.
- Modification des fonctions
- Assemblage de systèmes
- L'optimisation de la portée
- Résolution des problèmes
- Entretien
- Service
- Avis de non-responsabilité
- Déclaration de conformité

## DOWNLOAD, HERUNTERLADEN, TÉLÉCHARGER, DESARGAR

- EN **VIEW USER MANUAL ONLINE**
- DE **BENUTZERHANDBUCH ONLINE ANZEIGEN**
- FR **VOIR LE MANUEL DE L'UTILISATEUR EN LIGNE**
- NL **BEKIJK DE HANDLEIDING ONLINE**
- ES **VER MANUAL DEL USUARIO EN LÍNEA**

[downloads.tyroremotes.com](https://downloads.tyroremotes.com)



# 1. Introduction



Please read all instructions in this manual carefully before use

These operating instructions are intended for the technician and the end user. The operating instructions depend on the application, for which the end user is responsible. Keep these operating instructions carefully. Pass on all documents if the product is given to third parties.

## Intended use

The (end) user must store the handheld transmitter safely and in such a way that it cannot be used by unauthorized or unqualified persons.

This product is designed for wireless, radio control of machines. Application examples include: winches, pumps, gates, doors, lighting, and electrical control/axle control of trailers for special transportation. For significant other applications, please contact Tyro Remotes to avoid misuse of the product.

## Important information

The general conditions of sale, available on request or download at (<http://www.tyroremotes.com>), are valid at all times. After installation on the own system, the end user is responsible for the certification of the total system in combination with the remote control.

## Operating conditions handheld

The handheld transmitter cannot operate at temperatures below -30°C and above 60°C (-22°F to +140°F). Charging the handheld transmitter should only be done between 10°C and 45°C (+50°F to +113°F). For proper and safe operation of the handheld transmitter, it should be charged daily.

## Operating conditions receiver

The receiver cannot operate at temperatures below -40°C and above 80°C (-40°F to +176°F).

## Performance

The performance of our products depends on several factors. For a detailed explanation please visit: <http://www.tyroremotes.com/tyropedia>.

## Everything to your satisfaction?

Tyro makes every effort to deliver the products to your complete satisfaction. If this is not the case please contact us. Please observe the following deadlines:

- Visible defects and faults must be reported within 2 working days of receipt.
- Should Tyro Remotes not hear anything 2 weeks after delivery, then the delivery is considered approved.
- If there are other complaints, it is requested to report this to Tyro Remotes as soon as possible, but no later than 2 months after delivery.

## Declaration of conformity & certification

The complete declaration of conformity and certification can be found on the last pages of this user manual.

## Frequencies

It is important to know what frequency is allowed in the area where the product will be used. Whether or not a particular frequency is allowed depends on national legislation. Using the correct frequency is the responsibility of the end customer.

This frequency table shows which frequencies are allowed in a particular continent. Additional country-dependent product certification may be required.

Frequency table			
Frequency	434 MHz	915 MHz	2.4 GHz
Hopping protocol	LBT + AFA	FHSS	FHSS
Modulation type	GFSK	GFSK	GFSK
North America		✓	✓
Central & South America	✓	✓	✓
Brazil	✓		✓
Europe	✓		✓
Africa	✓		✓
Oceania	✓	✓	✓
Asia			✓
Japan			✓
Worldwide			✓



Check which frequency applies to your product by checking the system identification sticker

## Hopping protocol explanation

<b>LBT: Listen Before Transmit</b> <b>AFA: Automatic Frequency Agility</b>	With LBT, it first listens to see if the channel is free before sending the message. If the channel is busy, AFA ensures that another free channel is selected.
<b>FHSS: Frequency Hopping Spread Spectrum</b>	FHSS automatically hops across multiple frequency channels to reduce signal interference within a wide frequency spectrum. This allows multiple systems to operate side by side without interference.

## 2. Safety



### Caution: danger of injury or property damage!

To avoid dangerous situations, always observe the following rules:  
In case of deviation, ambiguity or doubt about the rules below, always contact Tyro Remotes.

<b>Check before use</b>	Always check before use that all keys and (emergency) stop button* function properly (*if present).
<b>Line of sight</b>	The operator must have a view of the hazard area at all times. Use the remote control only when there is line-of-sight connection to the application.
<b>Care</b>	Never leave the handheld transmitter unattended.
<b>Simulate</b>	After installation of the systems, it should be tested without turning on the main power of the application to prevent damage.
<b>ESD</b>	Always follow ESD guidelines if one may come into contact with internal parts to prevent damage.
<b>Instruction</b>	The end user should always be instructed (by the person in charge of the unit to be operated) on how to use the handheld remote safely in conjunction with the unit to be operated.
<b>Operation</b>	It is not recommended to operate the system with (thick) gloves that do not allow a good feel of the keys.
<b>Lifespan*</b>	*In the case of an ISO 13849-1 PL certified system, regardless of their condition, they must be replaced for safety reasons after 10 years (the expiration date).
<b>Out of range</b>	As an operator with an active system, always stay within range (situation dependent) to avoid risky situations.
<b>Damage</b>	In case of (visible) damage, always send the product to the manufacturer or distributor for repair to avoid risky situations. In case of (visible) damage, always send the product for repair to avoid risky situations.
<b>Installation</b>	Always have the system installed by a licensed electrician.
<b>Annual inspection</b>	The system should be checked annually, see section: Maintenance.
<b>Documentation</b>	Documentation should always be made available to the (end) user, instruction should be given if necessary.
<b>Risk of shutdown</b>	If multiple radio handheld transmitter devices within the range are operating on the same frequency, there is a chance that the system may inadvertently shut down.



### Warning: danger of property damage or personal injury!

After a safety shutdown of the system, it should not be put back into operation until the user has ascertained the safety of the operating and operating conditions.

### 3. Receiver dimensions & weight

Aquarius 2S - 6F / 10F		Aquarius 2S - 20F	
Weight:	480 gram / 1.05 lbs	Weight:	900 gram / 1.98 lbs

## 5. Receiver description

### Aquarius 2S

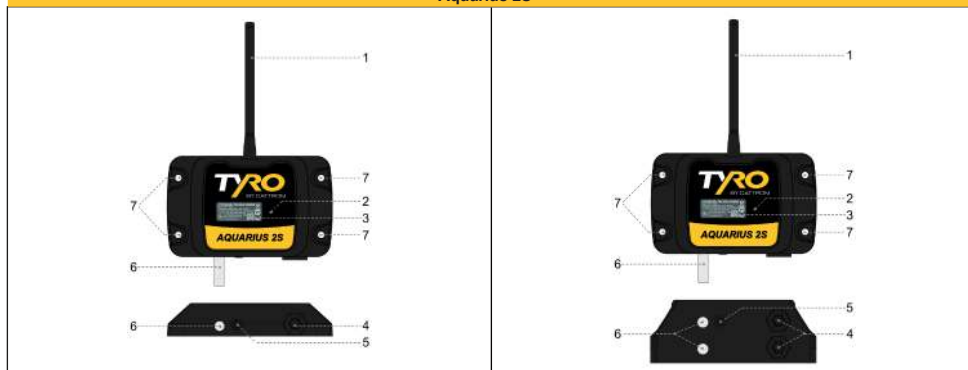

\*Actual receiver may differ

#### Physical characteristics:

1. Antenna	6. Connection cable(s)
2. Status-LED	• 6F / 10F 1x connection cable
3. Identification sticker	• 20F 2x connection cables
4. Fuse holder	7. Mounting holes Ø6mm
5. Pairing button	

## 4. Receiver specifications

### Aquarius 2S - Technical specifications

	434 MHz (LBT+AFA / 8 channels)	915 MHz (FHSS / 50 channels)	2.4 GHz (FHSS / 40 channels)
Frequency (+hopping protocol / channels)	433.150 - 434.375 MHz	902.500 - 927.000 MHz FCC 915.375 - 927.625 MHz AUS	2402 - 2480 MHz
Frequency range			
Antenna	SMA		
Communication mode	Duplex		
Transmission power	10.0 dBm at 434 MHz, 915 MHz   20 dBm at 2.4GHz		
Reaction time	Approx. 0.1 second		
Transmitters per receiver	434 MHz, 915 MHz: Max. 10 transmitters   2.4 GHz: Max. 8 transmitters		
Certification	CE, FCC, ISED, RCM, RED, ECE-R10		
Degree of protection	IP68		
Temperature range	-40°C / +80°C   -40°F / +176°F		
	6F	10F	20F
Max. Current load	4A per output, total max 10A	4A per output, total max 10A	4A per output, total max. 2x 10A
Max. Switching voltage	8 - 36 Vdc	8 - 36 Vdc	8 - 36 Vdc
Power supply	8 - 36 Vdc	8 - 36 Vdc	8 - 36 Vdc
Digital outputs	6	10	20
Digital inputs	2 + 2*	2*	2*
Analog outputs	4*	-	4*
Analog inputs	4*	-	4*
PWM	*	*	*
Bus networks	RS232*	RS232*	RS232*
Cable connection (std. 1.5 mtr / 3.18')	1x 10-core	1x 12-core	2x 12-core

\* On request

## 6. Receiver features

### Antenna

SMA antenna. The color ring on the antenna indicates the frequency.

- Red: 434 MHz
- Yellow: 915 MHz
- Pink: 2.4 GHz

### Status-LED

The Status LED on the Aquarius is a duo LED that can light up red or yellow for various indications.

Status-LED functionality	
<b>Transmit indicator</b>	
If a key is pressed, with active handheld transmitter	Status-LED flashes yellow
<b>Pairing</b>	
System is in "pairing mode"	Status-LED flashes red and yellow, fast (5x per sec.)
Pairing successfully completed	Status-LED flashes yellow (5x per sec.)
Pairing failed	Status-LED flashes red (5x per sec.)

### Identification sticker

- The system can be identified using the identification sticker. The sticker includes the serial number, type and kind of system.
- For an explanation of the identification sticker, see the section: 'System Identification'.

### Fuse holder

- Screw-out cap (flat screwdriver, socket 8 or socket wrench 19)
- Behind the cap is another cap which can be turned a quarter turn to the left with a flat screwdriver.
- The fuse holder can be taken out and the 10A fast glass fuse (5x20mm) can be replaced.

### Pairing button

- Button for pairing transmitter(s) and receiver.
- See the section "Pairing the transmitter to the receiver."

### Connection cable(s)

Depending on the version, the receiver may contain one or two cables.

- 6F: 10 core cable
- 10F: 12 core cable
- 20F: 2x 12 core cable

### Mounting holes

- Through the mounting holes, the receiver can be easily mounted in the desired location.
- Optional magnets can be mounted on the mounting holes.

## 7. Receiver functions

### Function key configuration

The characteristics of the function keys can be configured in two ways:

- Function key operation: momentary or latching
- Function key blocking: horizontal or vertical key lock, freely adjustable

The configuration can be at the default settings or set at the factory to a customer-specific configuration.

A configuration can be changed by the user as desired or reset to the default settings via the handheld transmitter.

### Function key operation

Function keys can be set to two modes:

- Momentary: key press = ON, key release = OFF
- Latching: key press and release = ON, key press and release again = OFF.

In the standard configuration, the function keys are set to momentary mode (key press = ON) / key release = OFF).

### Function key blocking

The simultaneous pressing of several function key combinations can be blocked. (e.g. 2 or 3 function keys simultaneously).

The function key locks can be configured in various ways by the user via the handheld transmitter:

Blocking can be configured in three ways:

- Horizontal (Function keys that are next to each other, e.g. 1&2, 3&4 e.t.c., cannot be used at the same time.
- Vertical (Function keys that are under each other, e.g. 1&3, 2&4 e.t.c., cannot be used at the same time.
- Other combinations can be set at the factory. In theory, any combination is possible.

In the standard configuration, the horizontal function keys cannot be used at the same time.



### Changing default function key configuration

To change the function key configuration, see the section: 'Changing functions'.



### Systems with customer-specific configuration

See customer-specific manual for operation and allowed function key combinations & function key locks.

### Out-of-range protection

If the handheld transmitter is out of range of the receiver, the receiver can no longer respond to commands from the handheld transmitter. If the handheld transmitter is activated again within range, the receiver switches on again. The status LED on the handheld transmitter will light up red for several seconds.

To prevent dangerous situations, an out-of-range protection can be set so that the receiver automatically turns off when:

- The handheld transmitter becomes out of range of the receiver.
- The battery of the handheld transmitter is empty.
- Out-of-range protection can be disabled or enabled (not for ISO 13849-1 certified systems).
- With ISO 13849-1 certified systems, out-of-range protection automatically kicks in. Please refer to the chapter: Safety Package.
- To enable or disable out-of-range protection, see chapter: Changing Functions.

### Line outputs

A line output becomes active as soon as the handheld transmitter is switched on with the ON button.

This can be used, for example, to turn on the main power of a machine.

- 0, 1 or 2 line outputs can be set.
- The default number of line outputs enabled (0, 1 or 2), depends on the receiver.
- For the default configuration, see the section: 'Changing functions'.

### Primary / Secondary instruction

Several Tyro Remotes handheld transmitters and receivers can be combined with each other in the sense that with 1 handheld transmitter several receivers can be operated or with several handheld transmitters 1 receiver. A so-called 1:n or n:1 configuration. In this type of configuration we speak of primary and secondary devices. A configuration has a maximum of one Primary with several Secondary devices. Two Primary devices cannot work with each other and two Secondary devices cannot work with each other either.



### Note: Standard configuration

Factory default configuration is 1 transmitter (Primary) with 1 or more receivers (Secondary).  
The combination multiple transmitters on multiple receivers is not possible.



### Note: Expanding a configuration

Should the configuration need to be expanded, the Primary and Secondary setting of the devices already in the configuration must be swapped in some cases.



### Changing and expanding the Primary / Secondary settings

For changing settings, contact the Tyro Remotes sales/service department to discuss configuration options.



## 8. Safety package

- Not applicable to the Aquarius 2S

## 9. System identification

### Identification via sticker

The system can be identified by an identification sticker on the receiver. The actual position of the sticker varies by product type. The figure below explains the contents of the handheld transmitter identification sticker.

#### Set sticker

When the system is part of a complete set, consisting of a handheld transmitter and a receiver, a set sticker is also generated. The set sticker can be found on the box and optionally in the front of the manual.

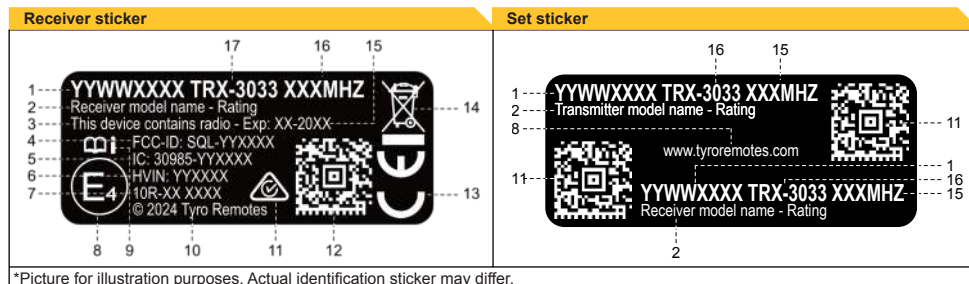

#### Identification sticker explanation

1.	Serial number, format (P)YYWW###(##). P = Prototype	10.	Copyright & Manufacturer
2.	Product name, specification of type / safe + rating	11.	RCM marking
3.	This product contains radio marking	12.	QR code with serial number
4.	FCC marking and ID number, based on product name and frequency or radio module	13.	CE certification
5.	IC marking and ID number, based on product name and frequency or radio module	14.	WEEE marking
6.	HVIN: hardware identification number, based on the product name and frequency or radio module	15.	Expiration date (ISO 13849-1)
7.	ECE-R10 / E4 certification number	16.	Frequency in MHz or GHz (434, 915 or 2.4)
8.	E4 marking	17.	Type number of the PCB (TX-, RX-, TRX + print nr. )
9.	For more information, refer to the user manual		

### QR code explanation

On the identification sticker is a scannable QR code. This code displays the relevant information about the system. For each product, this QR code is uniquely generated based on the system properties.



QR code in this example can be scanned to show a generic sample of the content

#### Example QR string

When the QR is scanned, a code string becomes visible. This contains the main system properties.

<b>P</b> 24011234	<b>V</b> 12.34.56	<b>C</b> 12.34.56	<b>S</b> 12.34.56	<b>R</b> 12.34.56	<b>H</b> 12.34	<b>B</b> 12.34.56	www.tyro.it/rcm
<b>1</b>	<b>2</b>	<b>3</b>	<b>4</b>	<b>5</b>	<b>6</b>	<b>7</b>	<b>8</b>

#### QR code explanation

<b>1</b>	P	Serial number, format (P)YYWW###(##). P = prototype
<b>2</b>	V	Software version CombiCode
<b>3</b>	C	Software version customer specific module (if present!)
<b>4</b>	S	Safety stack software versie
<b>5</b>	R	Radio software version
<b>6</b>	H	Hardware version
<b>7</b>	BJP	Bus / PLC software version
<b>8</b>	URL	URL optional

## 10. Pairing a handheld transmitter to the receiver



**Please note that all systems are already paired at the factory!**

This part can be skipped unless an additional or replacement handheld transmitter needs to be paired on to the receiver!





**Note: check primary/secondary setting!**



Check that the system is correctly configured with the correct Primary / Secondary settings. It may need to be adjusted. See section: Handheld Transmitter/Receiver Description: Primary / Secondary.

To pair a handheld transmitter (new, or additional) to the receiver, proceed as follows:

### Put the handheld transmitter in "pairing mode"

Musca 2S	Put the handheld transmitter in 'pairing mode':
	<ol style="list-style-type: none"> <li>1. Turn off the handheld transmitter by using the OFF-key.</li> <li>2. Press and hold function keys 1 and 2 simultaneously while the handheld transmitter is turned on with the ON-key.</li> <li>3. The status LEDs on the handheld transmitter flash red and green rapid alternately.</li> <li>4. The handheld transmitter is now in "pairing mode," the keys can now be released.</li> </ol>
Pyxis 2S	Put the handheld transmitter in 'pairing mode':
	<ol style="list-style-type: none"> <li>1. Turn off the handheld transmitter by using the OFF-key.</li> <li>2. Press and hold function keys 1 and 2 simultaneously while the handheld transmitter is turned on with the ON-key.</li> <li>3. The function LEDs indicate that "pairing mode" is active. (These light up from left to right)</li> <li>4. The handheld transmitter is now in "pairing mode," the keys can now be released.</li> </ol>
Cetus 2S	Put the handheld transmitter in 'pairing mode':
	<ol style="list-style-type: none"> <li>1. Turn off the handheld transmitter by using the ON/OFF-key.</li> <li>2. Press and hold function keys 1 and 2 simultaneously while the handheld transmitter is turned on with the ON/OFF-key.</li> <li>3. The status-LEDs indicate that "pairing mode" is active. (These light up from left to right)</li> <li>4. The handheld transmitter is now in "pairing mode," the keys can now be released.</li> </ol>

### Put the receiver in "pairing mode"

Aquarius 2S	Put the receiver in 'pairing mode':	
	<ol style="list-style-type: none"> <li>1. Locate the black pairing button on the bottom of the receiver.</li> <li>2. Press and hold the pairing button for 1 second. (See chapter: receiver description)</li> <li>3. The status-LED will flash red and yellow.</li> <li>4. The handheld transmitter is now in "pairing mode," the button can now be released.</li> </ol>	

### When both the devices are in 'pairing mode'

Step	Description
1.	When both the receiver and the handheld transmitter are in "pairing mode," the devices will find each other and can be successfully connected.
2.	When pairing the handheld transmitter to the receiver is successfully completed, the blinking of the status-LEDs will stop and the receiver status-LED will turn off (*if status LED is present).
3.	Pairing the handheld transmitter to the receiver is now complete.
4.	If the pairing was unsuccessful, the status-LED on the handheld transmitter will stop flashing and the buzzer will beep once.
5.	If no receiver is found, the system returns to "normal mode" after 60 seconds. Previously paired receivers remain active.
6.	In a standard configuration, 10 handheld transmitters can be linked per receiver at 434 / 915 MHz models. At 2.4 GHz, 8 handheld transmitter can be paired per transmitter.
8.	If pairing failed because too many handheld transmitters were stored, the pairing memory must first be cleared. (See the section: delete memory).

## Delete memory

To clear the memory of the handheld transmitter and/or receiver follow these steps:

### Delete memory (receiver)

The following steps apply to all receivers:

1. Locate the black pairing button on the bottom of the receiver.
2. Press and hold the pairing button for 8 seconds.
3. The status-LED will light yellow continuously.
4. When the memory has been successfully erased, the status-LED turns off.
5. After successful deletion, the receiver resets and goes into standby mode.



**See chapter: receiver description for locating all keys and buttons**

### Delete memory (transmitter)

The following steps apply to all handheld transmitters:

1. Turn off the handheld transmitter with the OFF-key.
2. Press and hold function keys 1 and 2 simultaneously for more than 8 seconds while the handheld transmitter is turned on.
3. The function-LEDs or status-LEDs light up.
4. When the memory has been successfully erased the status-LEDs or function-LEDs on the handheld transmitter turns off.
5. Systems equipped with an optional display will show a message.
6. After successful deletion, the handheld transmitter turns off.



**See chapter: handheld description for locating all keys and buttons**

## 11. Changing functions

From the factory, the system is set to momentary mode with horizontal function key lock active (see Table 2). To change functionality, a transmitter must first be programmed on the receiver. In a complete set, this is done at the factory.

With the following steps the functions can be changed.



**Note that changes must be set for all keys at once!**

When changing functionality, all already paired handtransmitters are deleted. Additional handheld transmitters must be paired again.

### Setup-mode (general)

First put the handheld transmitter in setup mode:

Step	Description
1.	Turn the handheld transmitter off by pressing the OFF-key for 1 second.
2.	Put the handheld transmitter in setup mode by holding function keys 1 and 2 while pressing the OFF-key for 5 seconds.
3.	The green status-LED will light up continuously, the handheld transmitter is now in setup mode. Release the function keys.
4.	If no key is pressed for 30 seconds, the handheld transmitter goes out of setup mode again.

Once setup mode is activated, the following can be changed via the steps described in table 1.

**Table 1**

Function key operation (Momentary / Latching)
Press the function key to be changed until the green status-LED flashes 2x. The function key changes to latching function. (The key lock is still active)
Return to default settings
Press the function key to be changed again. The function key changes to momentary function. The green status-LED flashes once.
Key lock
Table 2 shows which function keys cannot be used at the same time by default (locked) and which can be used together (function keys without locking)
To unlock function keys that are locked by default
Press both function keys until the green status-LED flashes 2x. The key lock changes to no lock.
Activating key lock for function keys that are not locked by default
Press both function keys until the green status-LED flashes 2x. The key lock is activated.
Return to default settings
Press the two function keys again until the green status-LED flashes once. The key lock changes to its original state.
Line output
1 line output
Press the ON-button until the green status-LED flashes 2x.
2 line outputs
Press the ON-button until the green status-LED flashes 3x.
No line outputs
Press the ON-button until the green status-LED flashes 1x.

<b>Out-of-range protection</b> (N/A for Musca 2S and ISO 13849-1 certified systems)
<b>Enable out-of-range protection</b>
Press the ON-key and function key 1 simultaneously until the green status-LED flashes 2x. The function changes to out of range protection enabled.
<b>Return to default settings (out of range protection off)</b>
Press the ON-key and function key 1 again simultaneously until the green status-LED flashes 1x. The function changes to out of range protection disabled.

### Send the customized configuration to the receiver

Step	Description
1.	Press the OFF-button on the handheld transmitter (within 30 seconds). The status-LED on the receiver flashes yellow 4x.
2.	The configuration has been paired to the receiver. The handheld transmitter is now out of setup mode and off (the green status LED on the handheld transmitter is off).
3.	The configuration has been paired to the receiver and the handheld transmitter is now out of setup mode and off (the green status LED on the handheld transmitter is off).

**Table 2: General version**

Depending on the receiver, there are default settings and configurable options.

**Check in advance which receiver is paired to the handheld transmitter for the correct settings!**

Default settings Aquarius 2S receiver			
Keys (general)	Default settings (1x flashing)	Option to be set (2x flashing)	Option to be set (3x flashing)
<b>Momentary / Latching</b>			
Function key 1	Momentary	Latching	-
Function key 2	Momentary	Latching	-
Function key ..	Momentary	Latching	-
<b>Horizontal key blocking</b>			
Function key 1 & 2	Mutually blocked	No blocking	-
Function key 3 & 4	Mutually blocked	No blocking	-
Function key .. & ..	Mutually blocked	No blocking	-
<b>Vertical key blocking</b>			
Function key 1 & 3	No blocking	Mutually blocked	-
Function key 2 & 4	No blocking	Mutually blocked	-
Function key .. & ..	No blocking	Mutually blocked	-
<b>Line outputs</b>			
Line output 1 & 2	Line outputs OFF	1 line output ON	2 line outputs ON
<b>Out of range protection* (Only applicable for rechargeable handheld transmitters)</b>			
ON-key & function key 1	OFF	ON	-
<b>Return to default settings</b>			
To reset the receiver to default settings, put the transmitter into setup mode and skip the changes in Table 1. Then send the unchanged setup to the receiver by pressing the OFF-key.			

## 12. System assembly (standard system)



**Note: For customer-specific products, the cable connection and assembly may differ**  
Always read the customer-specific manual, if applicable.



**Note: The receiver must always be connected after a main fuse (10A) from the power source!**

The location of the receiver is very important for the range, so please consider the points described in section 'Range Optimization'. See also <http://www.tyroremotes.com/tyropedia> for more range information. After connecting and mounting, test the operation of the system before turning on the main power. The receiver should always have that connected to the power source after a main fuse.

**Standard cable connection Aquarius 2S**

Key	Wire numbers - no line output (standard)				Wire numbers - 1 line output				Wire numbers - 2 line outputs			
	6F	10F	20F		6F	10F	20F		6F	10F	20F	
Version	6F	10F	20F		6F	10F	20F		6F	10F	20F	
Cable(s)	1	1	1	2	1	1	1	2	1	1	1	2
Mass	Green/Yellow	Green/Yellow	Green/Yellow	Green/Yellow	Green/Yellow	Green/Yellow	Green/Yellow	Green/Yellow	Green/Yellow	Green/Yellow	Green/Yellow	Green/Yellow
Supply 8-36 VDC	1	1	1	1	1	1	1	1	1	1	1	1
Line output 1	-	-	-	-	2	2	2	-	2	2	2	-
Line output 2	-	-	-	-	-	-	-	-	3	3	3	-
1	2	2	2	-	3	3	3	-	4	4	4	-
2	3	3	3	-	4	4	4	-	5	5	6	-
3	4	4	4	-	5	5	5	-	6	6	6	-
4	5	5	5	-	6	6	6	-	7	7	7	-
5	6	6	6	-	7	7	7	-	-	8	8	-
6	7	7	7	-	-	8	8	-	-	9	9	-
7	-	8	8	-	-	9	9	-	-	10	10	-
8	-	9	9	-	-	10	10	-	-	11	11	-
9	-	10	10	-	-	11	11	-	-	-	-	2
10	-	11	11	-	-	-	-	2	-	-	-	3
11	-	-	-	2	-	-	-	3	-	-	-	4
12	-	-	-	3	-	-	-	4	-	-	-	5
MENU	-	-	-	-	-	-	-	-	-	-	-	-
ON (I)	-	-	-	-	-	-	-	-	-	-	-	-
OFF (O)	-	-	-	-	-	-	-	-	-	-	-	-
Digital input 1 (DI 1)	8	-	-	-	8	-	-	-	8	-	-	-
Digital input 2 (DI 2)	9	-	-	-	9	-	-	-	9	-	-	-

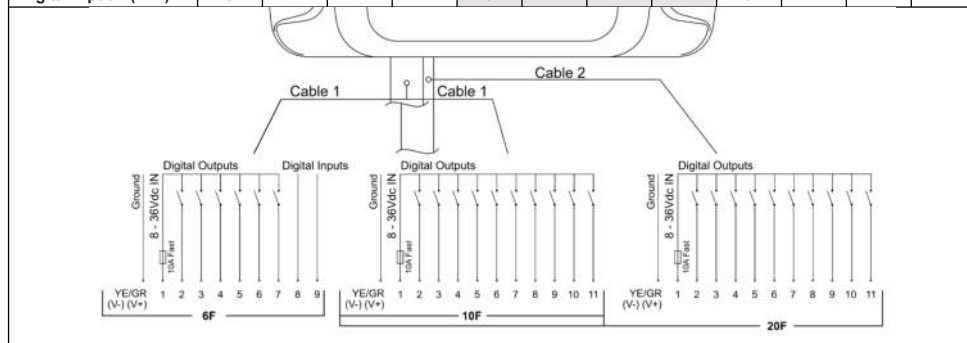

**With the Aquarius 2S 20F power and ground of both cables should preferably be connected to the same points. There is no turn-on priority or order.**



## 13. Range optimization

The location of the receiver is very important for the range, therefore take into account the points below to optimize the range of your system:

- Place multiple receivers at least 50 cm apart.
- Never place the receiver or antenna directly against or on a metal object, at least 50cm away from it.
- Mount the receiver or antenna a maximum of 3 to 4 meters above the working level; above or below the working level reduces the range.
- Place the receiver at least 50 cm away from motors or other equipment that can generate a force field.
- Never place the receiver with antenna in a control cabinet, cabin or similar (metal) enclosure.
- If the receiver must be placed in an unfavorable location, the antenna can be mounted in a different location using an antenna extension cable.
- If possible, ensure that there is a line-of-sight connection to the receiver during operation.
- In applications where work is done at the same height, such as winches or axle steering, it is better to mount the receiver and antenna vertically.
- In applications with large height differences such as elevator technology, it is better to mount the receiver with antenna horizontally.

### Range

The maximum indicated range is always an indication based on a measurement with line-of-sight connection without interference. The range cannot be guaranteed because it is always subject to variable environmental factors. In particular, shielding, reflections and shadows can limit the range.

Objects present between the transmitter and receiver, especially metal and reinforced concrete or absorbing objects such as trees, water or snow, have an unpredictable effect on the range. In general, range is optimal with a line-of-sight connection between the transmitter and receiver. See also <http://www.tyroremotes.nl/tyropedia> for more information on range.

### Frequencies

- Check that no wireless equipment is operating on the same frequency in the vicinity of the receiver; this may adversely affect system operation and range.

### Antenna mounting

- Put the antenna on the SMA connector, and tighten it. Check that the antenna is correctly and securely mounted.

## 14. Resolving problems

If the system is not working properly check the following points:

### The receiver does not respond to a command on the handheld transmitter

#### The receiver has no power supply.

Check that the receiver is properly connected and that the fuse is intact. \*Please note that not every receiver has a removable fuse.

#### The handheld transmitter is out of range of the receiver.

Make sure that the handheld transmitter is within range of the receiver and that there are no large (metal) objects between the handheld transmitter and the receiver, or the receiver's antenna. If necessary, an SMA antenna extension cable can be used to mount the receiver antenna in a different location.

#### The handheld transmitter is not paired to the receiver.

Follow the steps in the section, "Pairing a handheld transmitter to the receiver," to pair the handheld transmitter to the receiver.

#### Key lock is active.

Multiple keys may be pressed at the same time. This may prevent certain functions from being activated or blocked.

#### Key protection is active.

Check whether the hand transmitter is equipped with active key protection. The operation is listed in the handheld transmitter manual in chapter: Handheld transmitter functions.

### The handheld transmitter does not function

#### The handheld transmitter does not turn on when the ON-key is pressed.

The battery may be dead, recharge or replace the battery.

Make sure no other buttons are pressed other than the ON button.

For a handheld transmitter with an (emergency) stop button, the (emergency) stop button may be pressed, pull out the (emergency) stop button.

#### The handheld transmitter is out of range of the receiver.

Make sure the handheld transmitter is within range of the receiver and that there are no large (metal) objects between the handheld transmitter and the receiver, or the receiver's antenna.

#### The handheld transmitter does not switch on when the (emergency) stop button is pulled out

If this is not the case, the handheld transmitter is defective and the system should be submitted for repair. (\*Only if the handheld transmitter is equipped with an (emergency) stop button).

### The range is limited

#### The range is too limited.

If necessary, an SMA antenna can be installed at another location using an antenna extension cable to the receiver.

#### The receiver is not properly positioned.

Check that the receiver is not shielded by metal objects or sheet metal. The receiver should be positioned as high as possible. Refer to the guidelines in section "Range Optimization" in the receiver manual. Check that the antenna is tightly twisted onto the receiver's SMA connector.

### Range

The maximum range is always an indication based on a line-of-sight measurement without interference. Range cannot be guaranteed because it is always subject to variable environmental factors. In particular, shielding, reflections and shadows can limit the range.

Objects present between the handheld transmitter and the receiver, especially metal and reinforced concrete or absorbing objects such as trees, water or snow, have an unpredictable influence on the range. In general, range is optimal when there is a line-of-sight connection between the handheld transmitter and the receiver.

For more information on range and reach, see <http://www.tyroremotes.com/tyropedia>

### Frequencies

Check that no wireless equipment is operating on the same frequency in the vicinity of the receiver; this may adversely affect system operation and range.

## 15. Maintenance



**Note:** This section only applies to ISO 13849-1 PL certified systems

### Maintenance Checklist

To ensure that the system continues to function optimally over its lifetime, it is essential that annual maintenance will be performed. The checklist below should therefore be performed annually:

#### Check the system annually for the items listed below:

1. Visible damage to any of the devices, if so submit the set for repair.
2. Check that the system is still properly connected, if not repeat the check in the "System Assembly" section, in the receiver user manual (RX) .
3. Check the operation of the system by verifying that the system goes to a safe state when the safety inputs are made inactive. If not, submit the set for repair.
4. Check if the expiration date of the unit has expired, if so, the unit should no longer be used.

Year 1, after checking sign off here:		Year 6, after checking sign off here:	
Year 2, after checking sign off here:		Year 7, after checking sign off here:	
Year 3, after checking sign off here:		Year 8, after checking sign off here:	
Year 4, after checking sign off here:		Year 9, after checking sign off here:	
Year 5, after checking sign off here:		Year 10, replace the complete set	REPLACE COMPLETE SET

### Lifespan

A product version with an ISO 13849-1 PL certificate has a lifetime of up to 10 years, depending on use and maintenance. Each PL-certified product has an expiration date after which the product may no longer be used. This date is shown on the identification sticker at "exp. date". If the system is repaired, the expiration date remains the same. The stated lifetime comes from Performance Level certification (ISO 13849-1) and is not a form of warranty for planned product phase-out or quality assurance.

## 16. Service

If a Tyro Remotes remote controller is defective or in need of maintenance, the entire system (handheld transmitter and receiver) should be sent to Tyro Remotes for repair. For smooth handling, we ask that you complete the service form online and print out the confirmation email and send it with the system. The service form can be completed at <http://www.tyroremotes.com/support/> . Should there be any costs associated with the repair, this will always be notified in advance.

### Cleaning and maintenance:

- Do not use chemical cleaners or abrasives for cleaning, this may damage the control panel.
- It is recommended to use a damp cloth with light soapy water.
- In case of stubborn contamination contact Tyro Remotes, how best to remove the contamination.
- Never immerse the device in water or other liquids. Doing so may damage the device.
- Ensure that no moisture or liquid penetrates the device.

### Sales conditions and certification

All deliveries are made according to the general conditions of sale. This document can be requested from us, or downloaded from the website (<http://www.tyroremotes.com>). The products of Tyro Remotes are certified for many applications. These certificates can be requested from us. When mounting on an own system, the applicable machine directives belonging to the appropriate application must be taken into account. If a proprietary machine is equipped with Tyro Remotes remote control as standard, certification of the entire system - including remote control - is on your own responsibility.



### Warning!

Tyro Remotes is not responsible for possible personal, material and consequential damages resulting from improper use of this product in violation of the terms and instructions contained in this user manual.

## 18. Disclaimer

Tyro Remotes is a subsidiary of Cattron™. All information provided by Cattron™ and its representatives is believed to be accurate and reliable. All specifications are subject to change without notice. Responsibility for the use and application of the Cattron product lies with the end user, as Cattron and its representatives cannot be aware of all possible applications.

Cattron makes no warranties as to the absence of infringement or as to the suitability, merchantability or durability of Cattron products for specific or general use. Cattron Holdings Inc. or its affiliates or agents shall not be liable for incidental or consequential damages of any kind. All Cattron products are sold under the terms and conditions of sale, a copy of which will be provided upon request.

When used as a trade name, Cattron means Cattron Holdings Inc. or one or more subsidiaries of Cattron Holdings Inc. Cattron™, corresponding logos and other marks are trademarks or registered trademarks of Cattron Holdings Inc. Other trademarks are the property of third parties. Nothing herein provides a license under any intellectual property rights of Cattron or any third party.

This user manual has been compiled with the utmost care. Tyro Remotes accepts no liability for printing and typographical errors. Nevertheless, Tyro Remotes reserves the right to optimize and technically modify this user manual at any time. The images used may vary.

### Haftungsausschluss

Tyro Remotes ist eine Tochtergesellschaft von Cattron™. Alle von Cattron™ und seinen Vertretern bereitgestellten Informationen gelten als korrekt und zuverlässig. Alle Spezifikationen können ohne vorherige Ankündigung geändert werden. Die Verantwortung für die Verwendung und Anwendung des Cattron-Produkts liegt beim Endbenutzer, da Cattron und seine Vertreter nicht alle möglichen Anwendungen kennen können.

Cattron übernimmt keine Garantie für das Nichtvorhandensein von Rechtsverletzungen oder für die Eignung, Marktgängigkeit oder Haltbarkeit von Cattron-Produkten für bestimmte oder allgemeine Zwecke. Cattron Holdings Inc. oder seine Tochtergesellschaften oder Vertreter haften nicht für zufällige Schäden oder Folgeschäden jeglicher Art. Alle Cattron-Produkte werden gemäß den Verkaufsbedingungen verkauft, von denen auf Anfrage eine Kopie zur Verfügung gestellt wird.

Wenn Cattron als Handelsname verwendet wird, bedeutet Cattron die Cattron Holdings Inc. oder eine oder mehrere Tochtergesellschaften der Cattron Holdings Inc. Cattron™, die entsprechenden Logos und andere Marken sind Marken oder eingetragene Marken von Cattron Holdings Inc. Andere Marken sind das Eigentum von Dritten. Keine der hierin enthaltenen Informationen stellt eine Lizenz im Rahmen der geistigen Eigentumsrechte von Cattron oder Dritten dar.

Dieses Benutzerhandbuch wurde mit größtmöglicher Sorgfalt erstellt. Tyro Remotes übernimmt keine Haftung für Druck- und Schreibfehler. Tyro Remotes behält sich jedoch das Recht vor, dieses Benutzerhandbuch jederzeit zu optimieren und technisch zu ändern. Die verwendeten Bilder können variieren.

### Avis de non-responsabilité

Tyro Remotes est une filiale de Cattron™. Toutes les informations fournies par Cattron™ et ses représentants sont considérées comme exactes et fiables. Toutes les spécifications sont susceptibles d'être modifiées sans préavis. La responsabilité de l'utilisation et de l'application du produit Cattron incombe à l'utilisateur final, Cattron et ses représentants ne pouvant connaître toutes les applications possibles.

Cattron n'offre aucune garantie quant à l'absence de contrefaçon ou quant à l'adéquation, la qualité marchande ou la durabilité des produits Cattron pour un usage spécifique ou général. Cattron Holdings Inc. ou ses affiliés ou agents ne peuvent être tenus responsables des dommages accessoires ou indirects de quelque nature que ce soit. Tous les produits Cattron sont vendus conformément aux conditions générales de vente, dont une copie sera fournie sur demande.

Lorsqu'il est utilisé comme nom commercial, Cattron désigne Cattron Holdings Inc. ou une ou plusieurs filiales de Cattron Holdings Inc. Cattron™, les logos correspondants et les autres marques sont des marques commerciales ou des marques déposées de Cattron Holdings Inc. Les autres marques sont la propriété de tiers. Rien dans le présent document ne fournit une licence en vertu des droits de propriété intellectuelle de Cattron ou d'un tiers.

Ce manuel d'utilisation a été rédigé avec le plus grand soin. Tyro Remotes décline toute responsabilité en cas d'erreurs d'impression ou de typographie. Tyro Remotes se réserve néanmoins le droit d'optimiser et de modifier techniquement ce manuel d'utilisation à tout moment. Les images utilisées peuvent varier.

## Manufacturer details

### Tyro Products B.V.

Headquarters	
Address	Bedrijvenpark Twente 299
Postal code	7602 KK
City, Country	Almelo, The Netherlands
Phone number	+31 546 588 790
Website	www.tyroremotes.com

Production & Service	
Address	Minkovická 696
Postal code	46312
City, Country	Liberec, Czech Republic

# 17. Declaration of Conformity

## CE declaration



### Declaration of incorporation of partly completed machinery

In accordance with Annex IIA from the Machinery Directive 2014/42/EG

**TX-models:** TX-4042 Musca 2S      **RX-models:** RX-4042 Aquarius 2S  
TX-3033 Pyxis 2S                      RX-3033 Auriga 2S  
TRX-3033 Cetus 2S  
TX-3033 Pollux 2S

#### TYRO PRODUCTS B.V.

■ **Headquarters**  
Bedrijvencentrum Twente 299  
NL-7802 KK Almelo  
The Netherlands  
KVK: 08129497

■ **Production & Service**  
Minkovická 696  
46312 Liberec  
Czech Republic  
VAT: C2566638723

Tyro Remotes declares that a radio remote control system consisting of a transmitting unit listed from **TX-models** and a receiving unit listed from **RX-models** is in compliance with:

- Low Voltage Directive 2014/35/EU
- EMC Directive 2014/30/EU
- Radio Equipment Directive 2014/53/EG
- All relevant and essential health and safety requirements mentioned in appendix I of the Machinery Directive 2006/42/EG

The following harmonized standards and, where appropriate, technical standards, guidelines and specifications are used:

- EN 301 489-1/3:2019/2017/2023      Electro Magnetic Compatibility (EMC)
- EN 300 220-1/2:2017/18              Radiospectrum Matters (ERM)
- EN 62368-1:2014                      IT Equipment, Safety Part 1: General Demands
- EN 13849-1/2:2015/2012              Performance Level (PL)&Validation, certified as PL:c
- UN Agreement R10                    Vehicle type approval regarding electromagnetic compatibility

The radio remote control system shall not be put into service until the system in which it is installed has been tested with the essential health and safety requirements of the Machinery Directive Annex I. Compliance with the applicable guidelines apply only if installed and maintained as shown in the manual that comes with each new product.

Almelo, March 7th 2024

GJA Nijkrake, Engineering & Certificeringen

**EG type nr:**  
(currently in progress)



Rabobank, Nederland  
IBAN: NL38 RABO 0311 6406 80  
BIC/SWIFT: RABONL2U

Commerzbank, Deutschland  
IBAN: DE78 2674 0044 0583 0021 00  
BIC/SWIFT: COBADE33

CIC Banque, France  
IBAN: FR76 3002 7175 3300 0200 2800 544  
BIC/SWIFT: CMCIFRPP  
Code Banque: 30027, Code Guichet: 17533, Clé: 44

**Verklaring van inbouw van niet voltalloede machines, in overeenstemming met bijlage IIA van de machinerichtlijn 2014/42/EG**

Tyro Remotes verklaart dat een radioafstandsbedieningssysteem dat bestaat uit een zender-eenheid die is opgenomen in de lijst van TX-modellen en een ontvangende eenheid die is opgenomen in de lijst van RX-modellen, voldoet aan:

- Laagspanningsrichtlijn 2014/35/EU
- EMC-richtlijn 2014/30/EU
- Richtlijn radioapparatuur 2014/53/EG
- Alle relevante en essentiële veiligheids- en gezondheidseisen vermeld in bijlage I van de Machinerichtlijn 2014/42/EG

De volgende geharmoniseerde normen en, waar van toepassing, technische normen, richtlijnen en specificaties worden gebruikt:

- EN 301 489-1/3:2019/2017/2023 Elektromagnetische compatibiliteit (EMC)
- EN 300 220-1/2:2017/18 Radiospectrumkwesties (ERM)
- EN 62368-1:2014 IT-apparatuur, Veiligheid Deel 1: Algemene eisen
- UN-overeenkomst R10 Voertuigtypegoedkeuring met betrekking tot elektromagnetische compatibiliteit

Het radioafstandsbedieningssysteem mag niet in gebruik worden genomen voordat het systeem waarin het is geïnstalleerd, is getest met de essentiële veiligheids- en gezondheidseisen van de Machinerichtlijn Bijlage I. Naalving van de geldende richtlijnen is alleen van toepassing als het systeem wordt geïnstalleerd en onderhouden zoals aangegeven in de handleiding die bij elk nieuw product wordt geleverd.

**Einbauerklärung für unvollständige Maschinen, in Übereinstimmung mit Anhang IIA der Maschinenrichtlinie 2014/42/EG**

Tyro Remotes erklärt, dass ein Funkfernsteuerungssystem, bestehend aus einer Sendeeinheit, die als TX-Modelle aufgeführt ist, und einer Empfangseinheit, die als RX-Modelle aufgeführt ist, den Anforderungen entspricht:

- Niederspannungsrichtlinie 2014/35/EU
- EMV-Richtlinie 2014/30/EU
- Funkanlagen-Richtlinie 2014/53/EG
- Alle relevanten und grundlegenden Gesundheits- und Sicherheitsanforderungen, die in Anhang I der Maschinenrichtlinie 2014/42/EG aufgeführt sind

Die folgenden harmonisierten Normen und gegebenenfalls technischen Normen, Leitlinien und Spezifikationen werden verwendet:

- EN 301 489-1/3:2019/2017/2023 Elektromagnetische Verträglichkeit (EMV)
- EN 300 220-1/2:2017/18 Funkspektrumangelegenheiten (ERM)
- EN 62368-1:2014 IT-Einrichtungen, Sicherheit - Teil 1: Allgemeine Anforderungen
- UN-Konvention R10 Fahrzeugtypgenehmigung hinsichtlich elektromagnetischer Verträglichkeit

Die Funkfernsteuerungsanlage darf erst dann in Betrieb genommen werden, wenn die Anlage, in die sie eingebaut ist, auf die grundlegenden Sicherheits- und Gesundheitsanforderungen der Maschinenrichtlinie Anhang I geprüft wurde. Die Einhaltung der geltenden Richtlinien ist nur dann gegeben, wenn das System gemäß den Angaben in der mit jedem neuen Produkt gelieferten Anleitung installiert und gewartet wird.

**Declaration d'incorporation d'une quasi-machine, Conformément à l'annexe IIA de la directive Machines 2014/42/CE**

Tyro Remotes déclare qu'un système de télécommande radio composé d'une unité émettrice répertoriée comme modèles TX et d'une unité réceptrice répertoriée comme modèles RX est conforme à :

- Directive basse tension 2014/35/EU
- Directive CEM 2014/30/EU
- Directive sur les équipements radioélectriques 2014/53/CE
- Toutes les exigences pertinentes et essentielles en matière de santé et de sécurité énumérées à l'annexe I de la directive relative aux machines 2014/42/CE.

Les normes harmonisées suivantes et, le cas échéant, les normes techniques, les lignes directrices et les spécifications sont utilisées :

- EN 301 489-1/3:2019/2017/2023 / Compatibilité électromagnétique (CEM)
- EN 300 220-1/2:2017/18 / Questions relatives au spectre radioélectrique (ERM)
- EN 62368-1:2014 Équipements informatiques, Sécurité - Partie 1 : Exigences générales
- Convention de l'ONU R10 Homologation de type de véhicule concernant la compatibilité électromagnétique

Le système de radiocommande ne doit pas être mis en service tant que le système dans lequel il est installé n'a pas été testé par rapport aux exigences essentielles de santé et de sécurité de l'annexe I de la directive Machines. La conformité aux directives applicables n'est possible que si le système est installé et entretenu comme indiqué dans le manuel fourni avec chaque nouveau produit.

**Declaración de incorporación de una cuasi máquina, De conformidad con el anexo IIA de la Directiva sobre máquinas 2014/42/CE**

Tyro Remotes declara que un sistema de control remoto por radio compuesto por una unidad transmisora enumerada como modelos TX y una unidad receptora enumerada como modelos RX cumple con:

- Directiva de baja tensión 2014/35/UE
- Directiva CEM 2014/30/UE
- Directiva sobre equipos radioeléctricos 2014/53/CE
- Todos los requisitos esenciales y pertinentes en materia de salud y seguridad enumerados en el anexo I de la Directiva sobre máquinas 2014/42/CE.

Se utilizan las siguientes normas armonizadas y, en su caso, normas técnicas, directrices y especificaciones:

- EN 301 489-1/3:2019/2017/2023 Compatibilidad electromagnética (CEM)
- EN 300 220-1/2:2017/18 Cuestiones relativas al espectro radioeléctrico (ERM)
- EN 62368-1:2014 Equipos informáticos, Seguridad - Parte 1: Requisitos generales
- Convención de la ONU R10 Homologación de tipo de vehículo en materia de compatibilidad electromagnética

El sistema de radiocomando remoto no debe ponerse en servicio hasta que el sistema en el que está instalado haya sido probado con respecto a los requisitos esenciales de salud y seguridad del Anexo I de la Directiva de Máquinas. El cumplimiento de las directivas aplicables sólo es aplicable si el sistema se instala y mantiene como se indica en el manual suministrado con cada producto nuevo.

### FCC statement

This equipment has been tested and found to comply with the limits for a Class B digital device, pursuant to part 15 of the FCC Rules. These limits are designed to provide reasonable protection against harmful interference in a residential installation. This equipment generates, uses and can radiate radio frequency energy and, if not installed and used in accordance with the instructions, may cause harmful interference to radio communications. However, there is no guarantee that interference will not occur in a particular installation. If this equipment does cause harmful interference to radio or television reception, which can be determined by turning the equipment off and on, the user is encouraged to try to correct the interference by one or more of the following measures:

- Reorient or relocate the receiving antenna.
- Increase the separation between the equipment and receiver.
- Connect the equipment into an outlet on a circuit different from that to which the receiver is connected.
- Consult the dealer or an experienced radio/TV technician for help.

**Caution:** Any changes or modifications to this device not explicitly approved by manufacturer could void your authority to operate this equipment.

This device complies with part 15 of the FCC Rules. Operation is subject to the following two conditions: (1) This device may not cause harmful interference, and (2) this device must accept any interference received, including interference that may cause undesired operation.

### RF Exposure Information

The device has been evaluated to meet general RF exposure requirement. The device can be used in portable exposure condition without restriction.

### ISED statement: Portable (Receiver)



This device contains licence-exempt transmitter(s)/receiver(s) that comply with Innovation, Science and Economic Development Canada's licence-exempt RSS(s).

Operation is subject to the following two conditions:

1. This device may not cause interferences
2. This device must accept any interference, including interference that may cause undesired operation of the device.

The digital apparatus complies with Canadian CAN ICES-3 (B)/NMB-3(B).

This device meets the exemption from the routine evaluation limits in section 2.5 of RSS 102 and compliance with RSS 102 RF exposure, users can obtain Canadian information on RF exposure and compliance.

This equipment complies with Canada radiation exposure limits set forth for an uncontrolled environment.

This equipment should be installed and operated with a minimum distance of 20cm between the radiator & your body.



Cet appareil contient des émetteurs/récepteurs exempts de licence qui sont conformes aux RSS exemptés de licence d'Innovation, Sciences et Développement économique Canada.

L'exploitation est soumise aux deux conditions suivantes:

1. Cet appareil ne doit pas provoquer d'interférences.
2. Cet appareil doit accepter toute interférence, y compris les interférences susceptibles de provoquer un fonctionnement indésirable de l'appareil.

L'appareil numérique du ciem conforme canadien CAN ICES-3 (B)/NMB-3(B).

Cet appareil est conforme à l'exemption des limites d'évaluation courante dans la section 2.5 du cnr - 102 et conformité avec rss 102 de l'exposition aux rf, les utilisateurs peuvent obtenir des données canadiennes sur l'exposition aux champs rf et la conformité.

Cet équipement est conforme aux limites d'exposition aux rayonnements du Canada établies pour un environnement non contrôlé.

Cet équipement doit être installé et utilisé à une distance minimale de 20 cm entre le radiateur et votre corps.



<b>VERSION</b>	V1.0.1
<b>ART.CODE</b>	M1003

Copyright © 2022-2024 Tyro Products B.V., The Netherlands. All rights reserved.



**Manufacturer:**  
Tyro Remotes



**Bedrijvenpark Twente 299**  
7602 KK Almelo  
The Netherlands



**+31 (0)546 588 790**



**info@tyroremotes.eu**



**www.tyroremotes.eu**