User's Manual



RoHS

LIMIT L41

Microprocessor Based Limit Controller

Warning Symbol

This  Symbol calls attention to an operating procedure, practice, or the like, which, if not correctly performed or adhered to, could result in personal injury or damage to or destruction of part or all of the product and system. Do NOT proceed beyond a warning symbol until the indicated conditions are fully understood and met.

Use the Manual

- Installers Read Chapter 1, 2
- System Designer Read All Chapters
- Expert User Read Page 12

NOTE:

It is strongly recommended that a process should incorporate a LIMIT like L41 which will shut down the equipment at a preset process condition in order to preclude possible damage to products or system.

Information in this user's manual is subject to change.
without notice.

This manual is applicable for L41 units with software version
Prog 5.11 and later.

Copyright a January 2008, Future Design Controls, all rights reserved. No part of this publication may be reproduced, transmitted, transcribed or stored in a retrieval system, or translated into any language in any form by any means without the written permission of Future Design Controls.

Contents

| | Page No | | Page No |
|---|---------|---|---------|
| Chapter 1 Overview | | 3-4 PV Shift | 36 |
| 1-1 General | 5 | 3-5 Digital Filter | 36 |
| 1-2 Ordering Code | 6 | 3-6 Process Alarms | 37 |
| 1-3 Programming Port | 7 | 3-7 RS-485 Communication | 39 |
| 1-4 Keys and Display | 7 | 3-8 Retransmission | 39 |
| 1-5 Menu Overview | 12 | 3-9 Signal Conditioner DC Power Supply | 40 |
| 1-6 Limit Control Operation | 13 | 3-10 Remote Reset | 40 |
| 1-7 Parameter Descriptions | 16 | 3-11 Remote Lock | 41 |
| | | 3-12 Limit Annunciator | 41 |
| Chapter 2 Installation | | 3-13 Reference Data | 41 |
| 2-1 Unpacking | 22 | 3-14 Display Mode | 41 |
| 2-2 Mounting | 22 | | |
| 2-3 Wiring Precautions | 23 | Chapter 4 Calibration | |
| 2-4 Power Wiring | 24 | | 42 |
| 2-5 Sensor Installation Guidelines | 25 | Chapter 5 Specifications | |
| 2-6 Thermocouple Input Wiring | 25 | | 46 |
| 2-7 RTD Input Wiring | 26 | Appendix | |
| 2-8 Linear DC Input Wiring | 27 | A1 - Error Codes | 49 |
| 2-9 Event Input Wiring | 28 | | |
| 2-10 Output 1 Wiring | 39 | | |
| 2-11 Output 2 Wiring | 30 | | |
| 2-12 RS 485 | 31 | | |
| 2-13 Ma Retransmission | 33 | | |
| | | | |
| Chapter 3 Programming | | | |
| 3-1 Process Input | 34 | | |
| 3-2 Limit Control | 345 | | |
| 3-3 Setpoint Range | 35 | | |

Figures & Tables

| | Page No |
|---|---------|
| Figure 1-1 Programming Port Location | 7 |
| Figure 1-2 Front Panel Display | 8 |
| Figure 1-3 Power Up Sequence | 11 |
| Figure 1-4 High Limit Operation | 13 |
| Figure 1-5 Low Limit Operation | 14 |
| Figure 1-6 High/Low Limit Operation | 15 |
| Figure 2-1 Mounting Diagram | 22 |
| Figure 2-2 Lead Termination | 23 |
| Figure 2-3 Rear Terminal Connection Diagram | 23 |
| Figure 2-4 Power Supply Connections | 24 |
| Figure 2-5 Thermocouple Input Wiring | 25 |
| Figure 2-6 RTD Input Wiring | 26 |
| Figure 2-7 Linear Voltage Input Wiring | 27 |
| Figure 2-8 Linear Current Input Wiring | 27 |
| Figure 2-9 Event Input Wiring | 28 |
| Figure 2-10 Output 1 Wiring | 29 |
| Figure 2-11 Output 2 Wiring | 30 |
| Figure 2-12 RS-485 Wiring | 31 |
| Figure 2-13, 14 RS-232 Wiring | 32 |
| Figure 2-14 Retransmission Wiring | 33 |
| Figure 3-1 Conversion of Linear Process Input | 34 |
| Figure 3-2 Filter Characteristics | 36 |
| Figure 3-3 Normal Process Alarm | 38 |
| Figure 3-4 Latching Process Alarm | 38 |
| Figure 3-5 DC Power Supply Application | 40 |
| Figure 3-6 Remote Reset Application | 40 |
| Figure 3-7 Remote Lock Application | 41 |
| Figure 4-1 Flow chart for Manual Calibration | 43 |
| Figure 4-2 Cold Junction Calibration Setup | 44 |
| Figure 4-3 RTD Calibration | 45 |
| Table 1-1 Display Form of Characters | 9 |
| Table 5-1 Input Characteristics | 48 |

Chapter 1 Overview

1-1 General

The limit control **L41** is a microprocessor based high or low limit safety device with a latching output. The relay contacts open if an abnormal condition during the process is higher than the high limit set point or lower than the low limit set point.

The unit is powered by 90-250 VAC or an optional 11-26 VAC/VDC power supply. It incorporates a 2 amp. form C relay for limit control, a universal input which is fully programmable for RTD PT100, thermocouple types J, K, T, E, B, R, S, N, L, 0~60mVolt, Volt* and Milliamps*. Alternative main outputs are SSRD or Triac. A second optional output is available. This output can be configured for additional alarm or annunciator type output.

A DC power supply output option is available for external sensor or transmitter excitation power. The standard event input can be programmed for remote reset or remote lock signal input. Ma/VDC retransmission option of Process variable or setpoint is also available.

Digital communication RS-485 is available as an additional option. This option allows L91 to be integrated with supervisory control system.

Note; Retransmission and Communications is mutually exclusive.

Two kinds of method can be used to program L91.

1. use keys on front panel to program the unit manually.
2. Use a PC and setup software to program the unit via standard configuration port.

The input signal is digitized by using a 18-bit A to D converter. Its fast sampling rate (5 times/second) allows the L91 to respond quickly to input changes.

High accuracy, maximum flexibility, fast response and simple **user friendly prompts** are the main features of L91.

NOTE: * Volt and Milliamp Inputs are NOT FM Approved.

1-2 Ordering Code

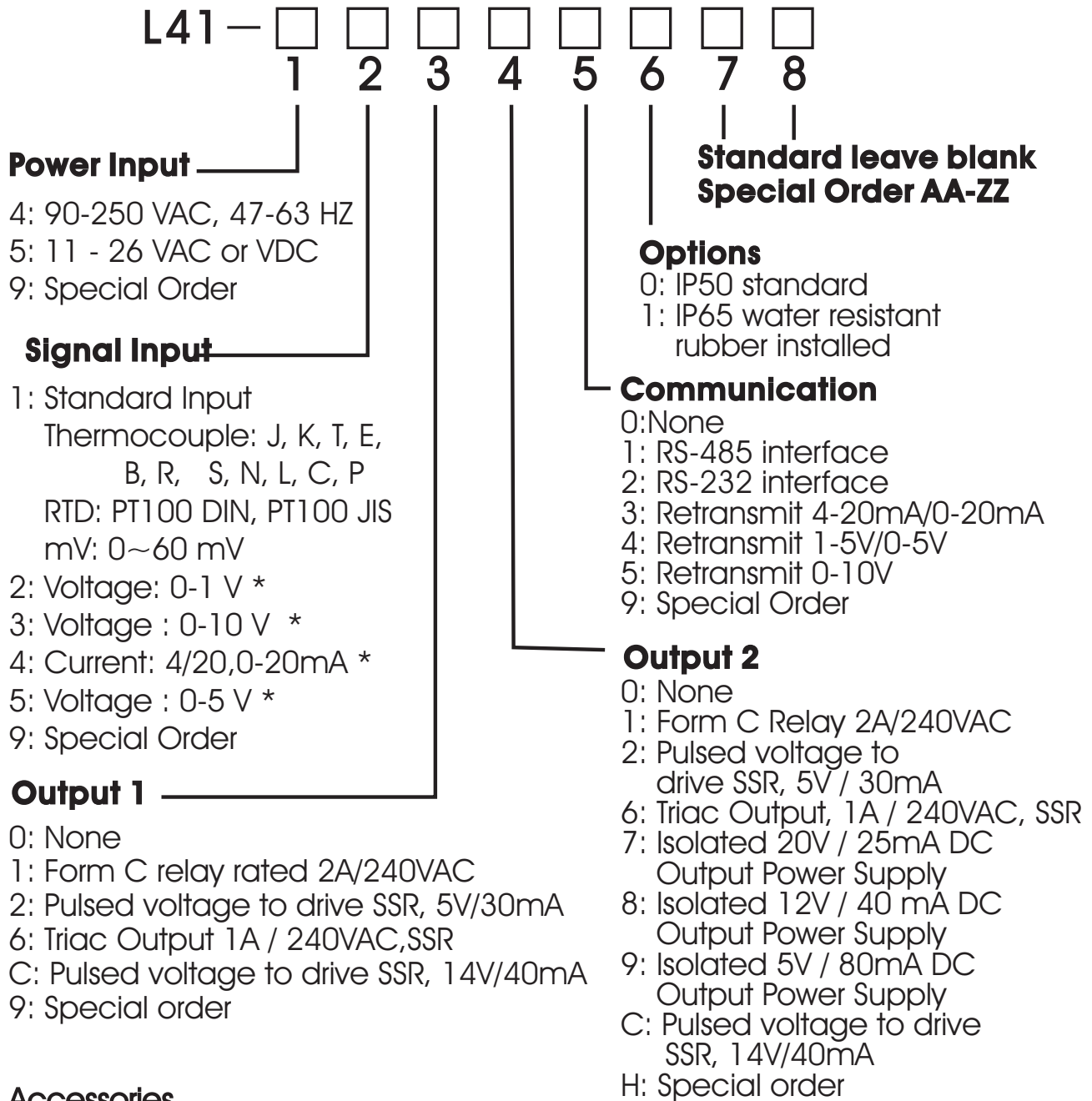

Accessories

- OM94-6 = Isolated 1A/240VAC Triac Output Module (SSR)
- OM94-7 = 14V/40mA SSR Drive Module
- DC94-1 = Isolated 20V / 25mA DC Output Power Supply
- DC94-2 = Isolated 12V / 40mA DC Output Power Supply
- DC94-3 = Isolated 5V / 80mA DC Output Power Supply
- CM94-1 = Isolated RS-485 Interface Module
- CM94-2 = Isolated RS-232 Interface Module
- CM94-3 = Isolated 4-20mA / 0-20mA Retransmission Module
- CM94-4 = Isolated 1-5V / 0-5V Retransmission Module
- CM94-5 = Isolated 0-10V Retransmission Module
- CC91-3 = Programming port cable for L41
- UMOL411A = L41 User's Manual

*NOTE: Input OPTIONS 2, 3, 4, 5 & 9 ARE NOT FM APPROVED

1-3 Programming Port and DIP Switch

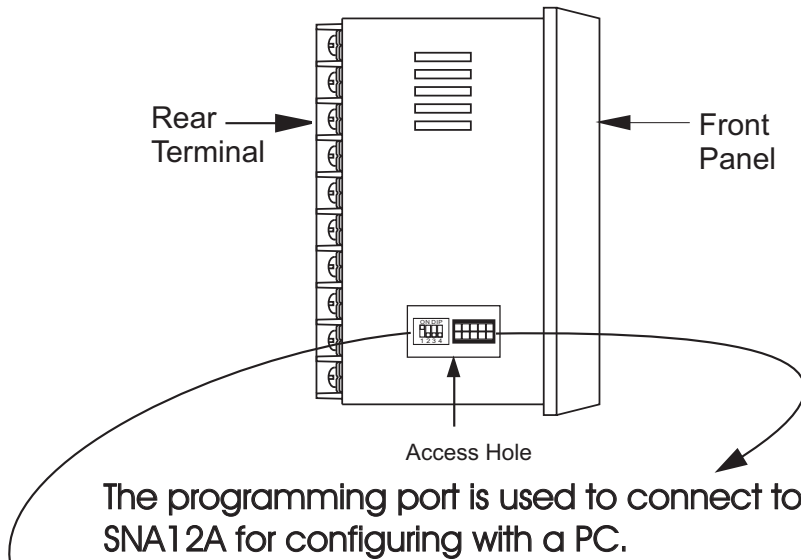

Figure 1.1 Access Hole Overview

| | | DIP Switch | | | |
|--------------|-------------|------------|---|---|---|
| | | ■:ON □:OFF | | | |
| | | 1 | 2 | 3 | 4 |
| Input Select | TC, RTD, mV | ■ | □ | | |
| | 0-1V, 0-10V | □ | ■ | | |
| | 0-20 mA | ■ | ■ | | |

Table 1.1 DIP Switch Configuration

1-4 Keys and Display

KEYPAD OPERATION

SCROLL KEY

This key is used to:

1. Select a set point to be displayed.
2. Select a parameter to be viewed or adjusted.
3. Advance display from a parameter code to the next parameter code

ENTER KEY  4 seconds, 6 seconds

Press the scroll key for 4 seconds the display will enter the setup menu. Press this key for 6 seconds to enter the calibration mode.

UP KEY 

This key is used to increase the selected parameter value during the lock indicator is off.

DOWN KEY 

This key is used to decrease the selected parameter value during the lock indicator is off.

RESET KEY 

This key is used to:

- 1.Reset the limit condition after the process is within the limit.
- 2.Revert the display to the normal display.
- 3.Reset the latching alarm, once the alarm condition is removed.
- 4.Reset the limit annunciator.

Note: If the RESET key is left pressed, only ONE reset operation will occur. If the unit subsequently goes into a state where reset is required again, the RESET key (or remote reset contacts) must be released (opened) and pressed (closed) again.

UNLOCK KEY  4 seconds

Press the RESET key for 4 seconds to enable up/down key function, and the lock indicator will be extinguished. However, this function is disabled when the EI input pins are closed and remote lock is selected for EIFN (Event input function). **See section 3-11.**

The reference data are reset as long as the reset key is pressed for 4 seconds. **See section 3-13.**

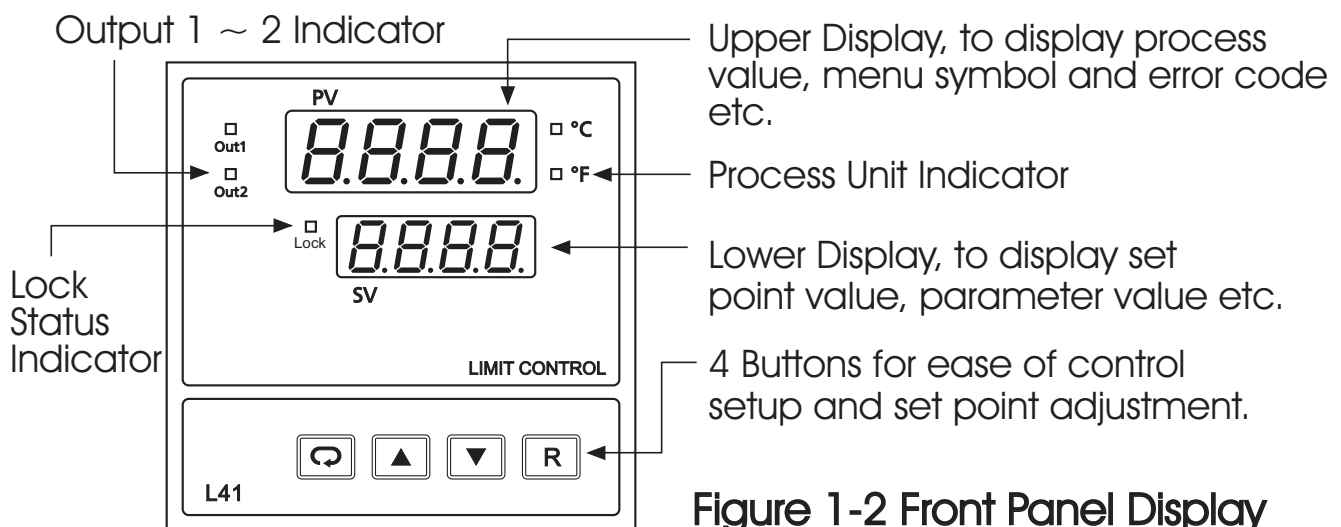

Figure 1-2 Front Panel Display

DISPLAY FORM

Table 1-1 Display Form of Characters

| | | | | | | | | | | | |
|---|----------|---|----------|---|----------|---|----------|---|----------|---|----------|
| A | <i>A</i> | E | <i>E</i> | I | <i>I</i> | N | <i>n</i> | S | <i>S</i> | X | |
| B | <i>b</i> | F | <i>F</i> | J | <i>J</i> | O | <i>o</i> | T | <i>t</i> | Y | <i>y</i> |
| C | <i>C</i> | G | <i>G</i> | K | <i>K</i> | P | <i>P</i> | U | <i>u</i> | Z | |
| c | <i>c</i> | H | <i>H</i> | L | <i>L</i> | Q | | V | <i>v</i> | ? | <i>?</i> |
| D | <i>d</i> | h | <i>h</i> | M | <i>m</i> | R | <i>r</i> | W | | = | <i>=</i> |

▴: These characters are displayed differently.

How to display a 5-digit number :

For a number with decimal point the display will be shifted one digit right:

-199.99 will be displayed as -199.9, 4553.6 will be displayed as 4553

For a number without decimal point the display will be divided into two alternating phases:

-19999 will be displayed as:

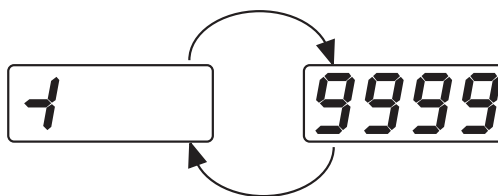

45536 will be displayed as:

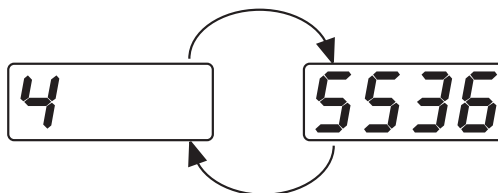

-9999 will be displayed as:

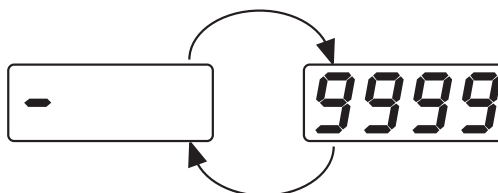

NORMAL DISPLAY

During normal operation, the unit can be configured to display the high limit or low limit set point (HSP1 or LSP1 dependent on OUT1 selection) or the word SAFE.

ABNORMAL DISPLAY

Whenever the process is outside the normal range, the process value will be displayed.

SENSOR BREAK DISPLAY

If a break is detected in the sensor circuit, the display will show:

SEn.b

A-D FAILURE DISPLAY

If failure is detected in the A-D converter circuit, the display will show:

Ad.Er

POWER UP SEQUENCE

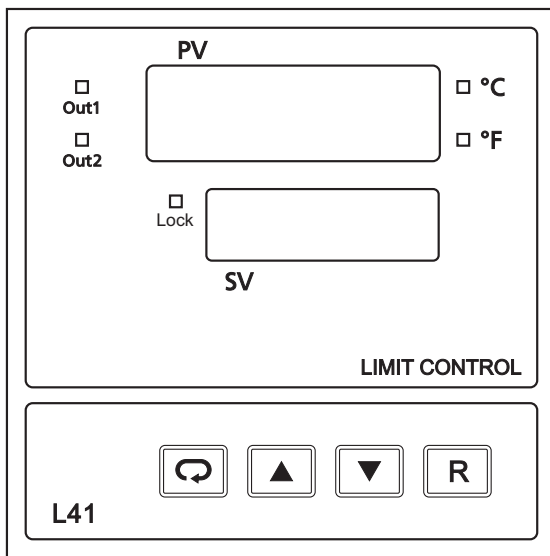

All segments of display and indicators are left off for 0.5 second.

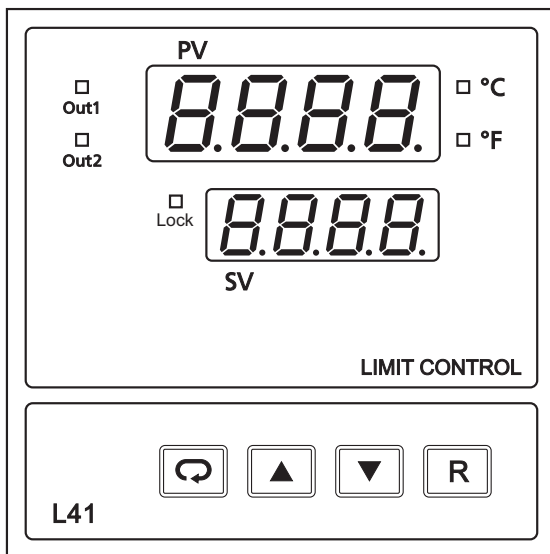

All segments of display and indicators are lit for 1.5 seconds.

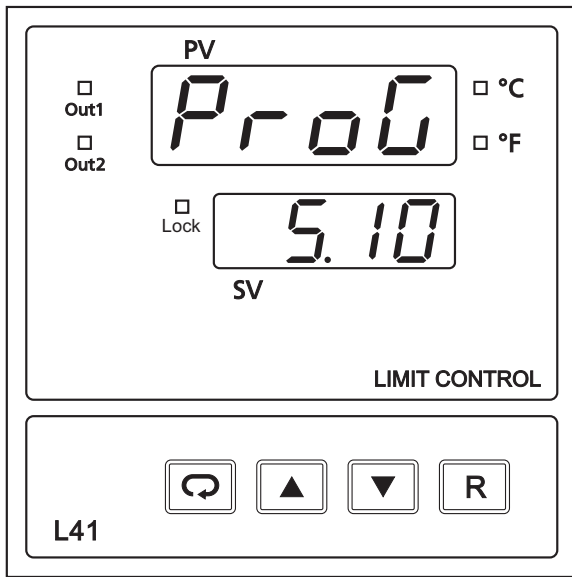

Display program code of the product for 1.5 seconds. The left diagram shows program no.5 with version 10.

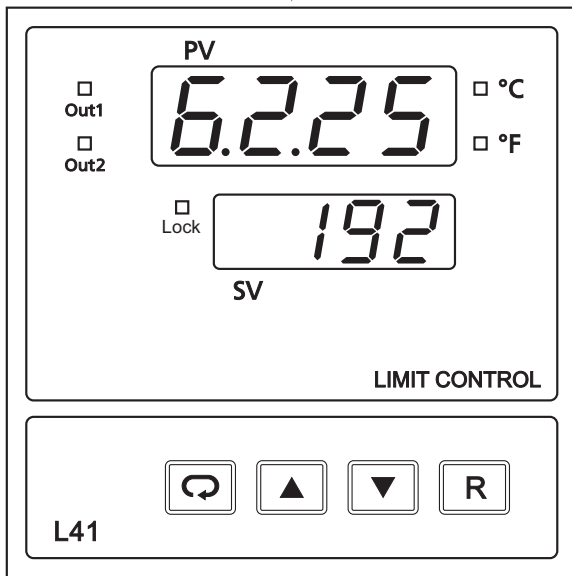

Display Date Code for 1.5 seconds. The left diagram shows Year 2006, Month February (2), Date 25th. This means that the product is produced on February 25th, 2006. Note that the month code **A** is for **October**, **B** is for **November** and **C** is for **December**.

Display the serial number (001 ~ 999) for 1.5 seconds.

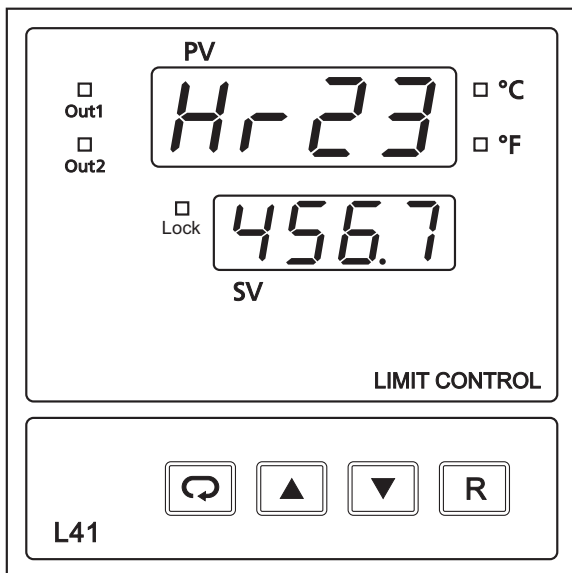

Display the hours used for 1.5 seconds. The left diagram shows that the unit has been used for 23456.7 hours since production.

Verify all electrical connections have been properly made before applying power to the unit.

During power up, a self-test procedure is performed within 6.5 seconds. During self-test period all outputs are left off. When the self-test procedure is complete, the unit

**Figure 1-3
Power Up Sequence**

1-5 Menu Overview

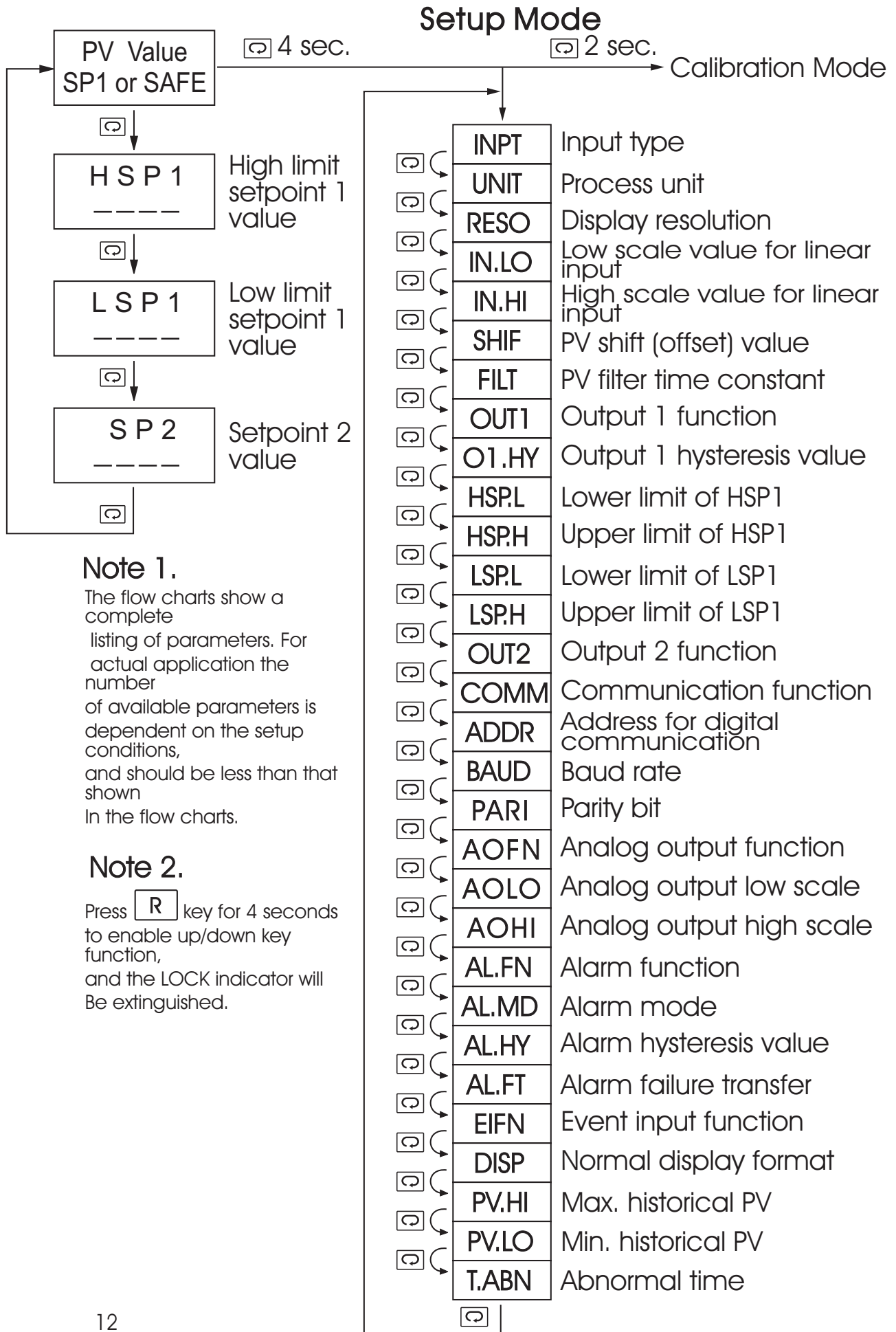

Note 1.

The flow charts show a complete listing of parameters. For actual application the number of available parameters is dependent on the setup conditions, and should be less than that shown in the flow charts.

Note 2.

Press **R** key for 4 seconds to enable up/down key function, and the LOCK indicator will be extinguished.

1-6 Limit Control Operation

HIGH LIMIT OPERATION

If Hi. is selected for OUT1, the unit will perform high limit control. When power is applied the OUT1 relay is de-energized. After 6.5 seconds self-test period, if the process is below the high limit set point (HSP1), the output 1 relay will be energized and OP1 indicator will go off. If the process goes above the high limit set point, the relay will be de-energized, the OP1 indicator will go on and the display will show the process value. After the process falls below the high limit set point and the RESET key is pressed or the remote reset input is applied, the relay will be energized and the OP1 indicator will go off.

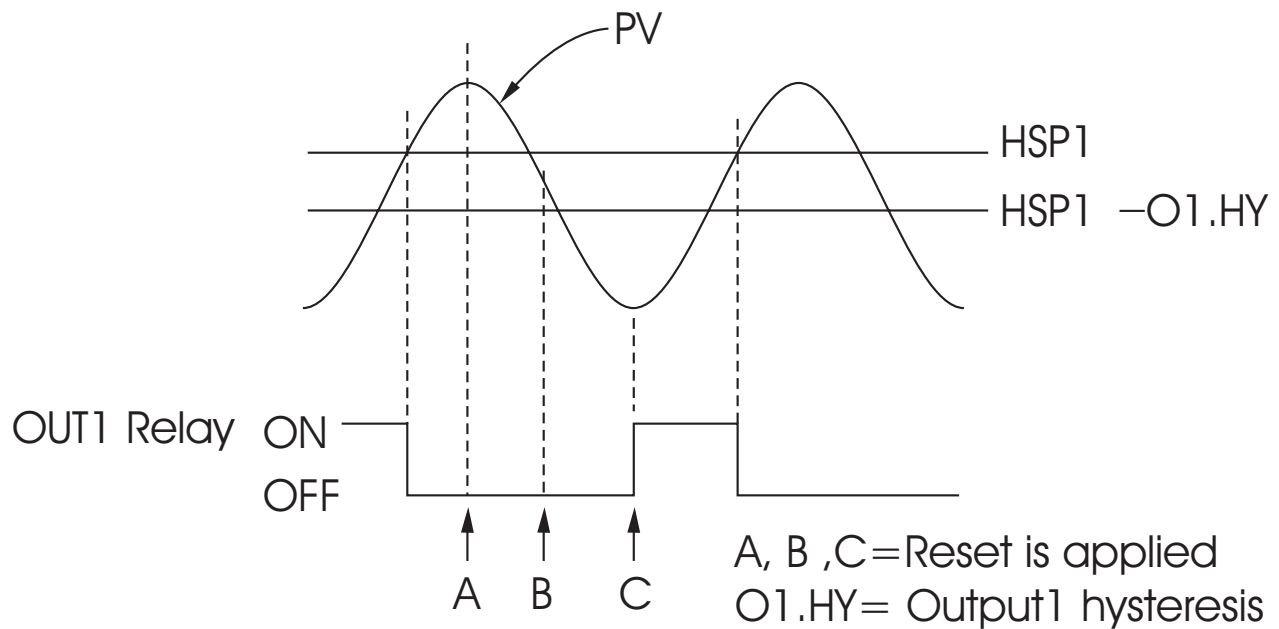

Figure 1-4 High Limit Operation

LOW LIMIT OPERATION

If Lo. is selected for OUT1, the unit will perform low limit control. When power is applied the OUT1 relay is de-energized. After 6.5 seconds self-test period, if the process is above the low limit set point (LSP1), the output 1 relay will be energized and OP1 indicator will go off. If the process goes below the low limit set point, the relay will be de-energized, the OP1 indicator will go on and the display will show the process value. After the process rises above the low limit set point and the RESET key is pressed or the remote reset input is applied, the relay will be energized and the OP1 indicator will go off.

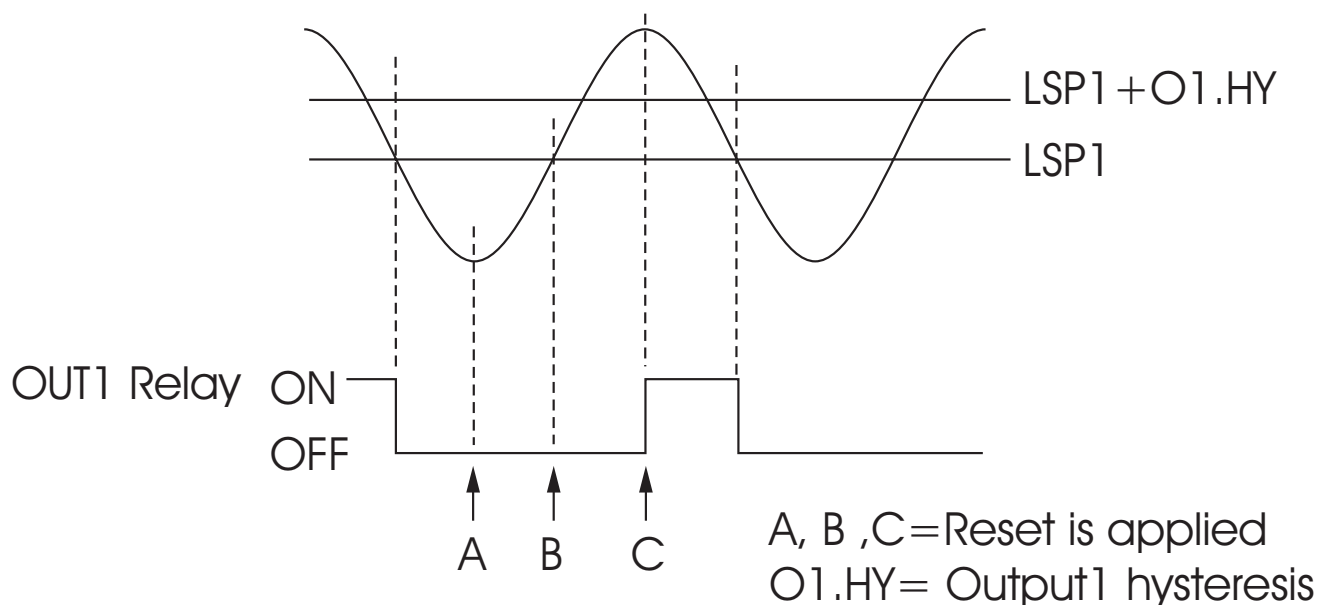
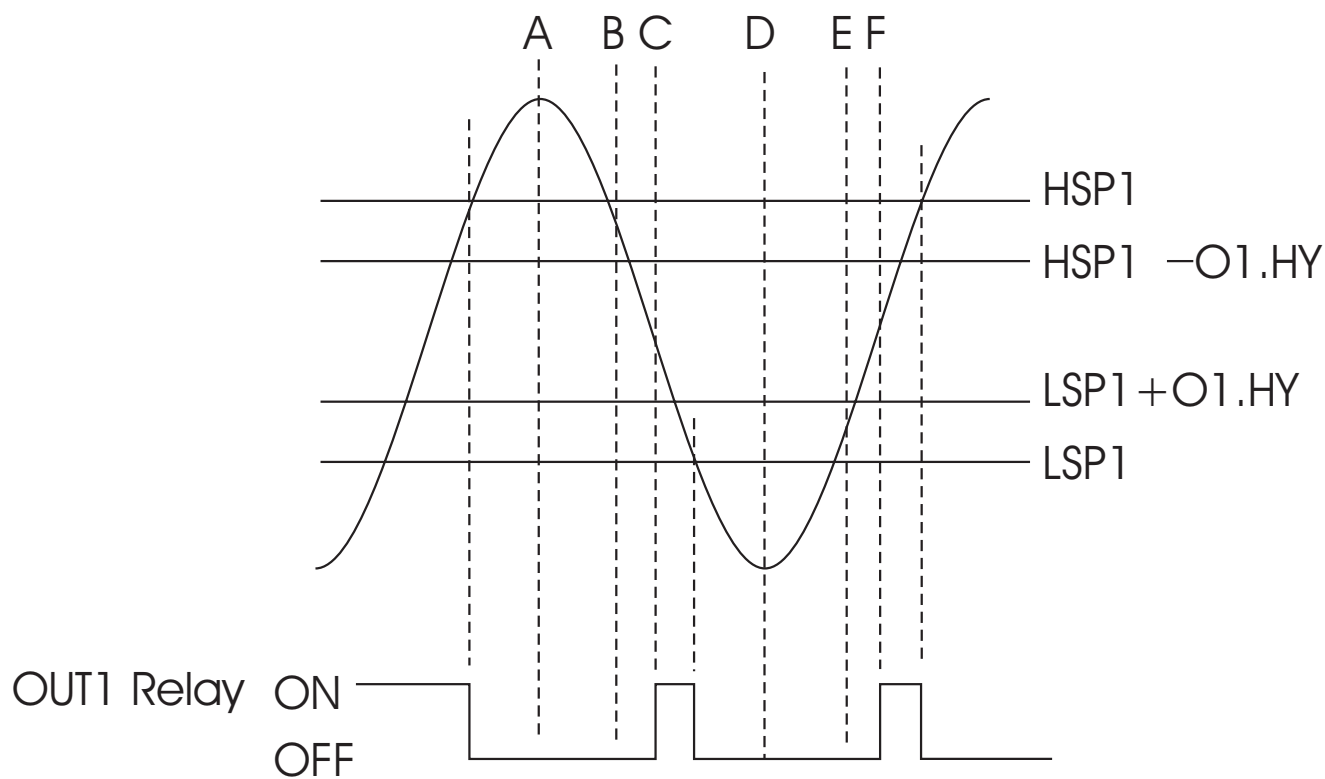

Figure 1-5 Low Limit Operation

HIGH/LOW LIMIT OPERATION

If Hi.Lo is selected for OUT1, the unit will perform high/low limit control. When power is applied the OUT1 relay is de-energized. After 6.5 seconds self-test period, if the process is below the high limit set point (HSP1) and above the low limit set point (LSP1), the output 1 relay will be energized and OP1 indicator will go off. If the process goes above the high limit set point or below the low limit set point, the relay will be de-energized, the OP1 indicator will go on and the display will show the process value. After the process is within the normal operation range, and the RESET key is pressed or the remote reset input is applied, the relay will be energized and the OP1 indicator will go off.



A, B, C, D, E, F = Reset is applied
O1.HY = Output1 hysteresis

Figure 1 -6 High/Low Limit Operation

1-7 Parameter Descriptions

| Parameter Notation | Parameter Description | Range | Default Value |
|--------------------|--------------------------------|--|----------------------|
| HSP1 | High Limit Set point 1 | Low: HSP.L High: HSP.H | 100.0 C (212.0 F) |
| LSP1 | Low Limit Set point 1 | Low: LSP.L High: LSP.H | 0 C (32.0 F) |
| SP2 | Set point 2 Value for Output 2 | Low: -19999 High: 45536 | 90.0 C (194.0 F) |
| INPT | Input Type Selection | 0 <i>J_tC</i> : J type thermocouple 1 <i>K_tC</i> : K type thermocouple 2 <i>T_tC</i> : T type thermocouple 3 <i>E_tC</i> : E type thermocouple 4 <i>B_tC</i> : B type thermocouple 5 <i>R_tC</i> : R type thermocouple 6 <i>S_tC</i> : S type thermocouple 7 <i>N_tC</i> : N type thermocouple 8 <i>L_tC</i> : L type thermocouple 9 <i>C_tC</i> : C type thermocouple 10 <i>P_tC</i> : P type thermocouple 11 <i>PT.dn</i> : PT100 ohms DIN curve 12 <i>PT.JS</i> : PT100 ohms JIS curve | 1 (0) |

| Parameter Notation | Parameter Description | Range | Default Value |
|--------------------|----------------------------------|---|---------------|
| INPT | Input Type Selection | 13 <i>4-20</i> : 4~20 mA linear current 14 <i>0-20</i> : 0~20 mA linear current 15 <i>0-60</i> : 0~60 mV linear voltage 16 <i>0-1V</i> : 0~1 V linear voltage 17 <i>0-5V</i> : 0~5 V linear voltage 18 <i>1-5V</i> : 1~5 V linear voltage 19 <i>0-10</i> : 0~10V linear voltage | 1 (0) |
| UNIT | Process Unit | 0 <i>0C</i> : Degree C unit 1 <i>0F</i> : Degree F unit 2 <i>Pu</i> : Process unit | 0 (1) |
| RESO | Display Resolution | 0 <i>no.dP</i> : No decimal point 1 <i>1-dP</i> : 1 decimal point 2 <i>2-dP</i> : 2 decimal point 3 <i>3-dP</i> : 3 decimal point | 1 |
| IN.LO | Low Scale Value for Linear Input | Low: -19999 High: IN.HI | 0 |

| Parameter Notation | Parameter Description | Range | Default Value |
|--------------------|-----------------------------------|---|---------------|
| IN.HI | High Scale Value for Linear Input | Low: IN.LO High: 45536 | 100.0 |
| SHIF | PV Shift (offset) Value | Low: -200.0 C (-360.0 F) High: 200.0 C (360.0 F) | 0.0 |
| FILT | PV Filter Time Constant | <p>0 0 : 0 second time constant</p> <p>1 0.2 : 0.2 second time constant</p> <p>2 0.5 : 0.5 second time constant</p> <p>3 1 : 1 second time constant</p> <p>4 2 : 2 seconds time constant</p> <p>5 5 : 5 seconds time constant</p> <p>6 10 : 10 seconds time constant</p> <p>7 20 : 20 seconds time constant</p> <p>8 30 : 30 seconds time constant</p> <p>9 60 : 60 seconds time constant</p> | 2 |
| OUT1 | Output 1 Function | <p>2 H_i : High limit control</p> <p>3 L_o : Low limit control</p> <p>4 H_i . L_o : High/Low limit control</p> | 2 |

| Parameter Notation | Parameter Description | Range | Default Value |
|--------------------|---------------------------|--|------------------------|
| O1.HY | Output 1 Hysteresis Value | Low: 0.1 High: 10.0 C (18.0 F) | 0.1 |
| HSP.L | Lower Limit of HSP1 | Low: -19999 High: HSP.H | 0 C (32.0 F) |
| HSP.H | Upper Limit of HSP1 | Low: HSP.L High: 45536 | 1000.0 C (1832.0 F) |
| LSP.L | Lower Limit of LSP1 | Low: -19999 High: LSP.H | -100.0 C (-148.0 F) |
| LSP.H | Upper Limit of LSP1 | Low: LSP.L High: 45536 | 0 C (32.0 F) |
| OUT 2 | Output 2 Function | 0 <i>nonE</i> : No function 1 <i>dCPS</i> : DC power supply output 2 <i>ALn</i> : Alarm output 3 <i>L_An</i> : Limit annunciator | 2 |
| COMM | Communication function | 0 <i>nonE</i> : No communication 1 <i>rtu</i> : Modbus RTU mode protocol 2 <i>4-20</i> : 4-20mA retransmission output 3 <i>0-20</i> : 0-20mA retransmission output 4 <i>0-5V</i> : 0-5V retransmission output 5 <i>1-5V</i> : 1-5V retransmission output 6 <i>0-10</i> : 0-10V retransmission output | 1 |

| Parameter Notation | Parameter Description | Range | Default Value |
|--------------------|------------------------------------|--|-----------------|
| ADDR | Address Assignment of Digital COMM | Low: 1 High: 255 | 1 |
| BAUD | Baud Rate of Digital COMM | 0 0.3 : 0.3 Kbits/s baud rate 1 0.6 : 0.6 Kbits/s baud rate 2 1.2 : 1.2 Kbits/s baud rate 3 2.4 : 2.4 Kbits/s baud rate 4 4.8 : 4.8 Kbits/s baud rate 5 9.6 : 9.6 Kbits/s baud rate 6 14.4 : 14.4 Kbits/s baud rate 7 19.2 : 19.2 Kbits/s baud rate 8 28.8 : 28.8 Kbits/s baud rate 9 38.4 : 38.4 Kbits/s baud rate | 5 |
| PARI | Parity Bit of Digital COMM | 0 EVEN : 8 bit even parity 1 odd : 8 bit odd parity 2 none : 8 bit none parity | 0 |
| AOFN | Analog Output Function | 0 PU : Process value 1 HSP 1 : High Limit Set point 1 2 LSP 1 : Low Limit Set point 1 | 0 |
| AOLO | Analog Output Low Scale Value | Low: -19999 High: 45536 | 0 C (32.0 F) |

| Parameter Notation | Parameter Description | Range | Default Value |
|--------------------|--|--|----------------------|
| AOHI | Analog Output High Scale Value | Low: -19999 High: 45536 | 100.0 C (212.0 F) |
| AL.FN | Alarm function | 6 <i>PYHA</i> : Process value high alarm 7 <i>PYLA</i> : Process value low alarm | 6 |
| AL.MD | Alarm mode | 0 <i>nor\bar{n}</i> : Normal alarm action 1 <i>Ltch</i> : Latching alarm action | 0 |
| AL.HY | Alarm hysteresis value | Low: 0.1 High: 10 BC (18.0 BF) | 0.1 |
| AL.FT | Alarm failure transfer | 0 <i>off</i> : Alarm output goes off as unit fails 1 <i>on</i> : Alarm output goes on as unit fails | 1 |
| EIFN | Event input function | 0 <i>nonE</i> : No event function 1 <i>rESE</i> : Remote reset for output 1, output 1 on. 2 <i>Lock</i> : Remote lock for the unit | 0 |
| DISP | Normal display format | 0 <i>SAFE</i> : Display SAFE 1 <i>HSP1</i> : Display the value of HSP1 2 <i>LSP1</i> : Display the value of LSP1 | 0 |
| PV.HI | Historical Max. value of PV | Low: -19999 High: 45536 | — |
| PV.LO | Historical Min. value of PV | Low: -19999 High: 45536 | — |
| T.ABN | Accumulated time during abnormal condition | Low: 0 High: 6553.5 minutes | — |

Chapter 2 Installation



Dangerous voltages capable of causing death are sometimes present in this instrument. Before installation or beginning any troubleshooting procedures the power to all equipment must be switched off and isolated. Units suspected of being faulty must be disconnected and removed to a properly equipped workshop for testing and repair. Component replacement and internal adjustments must be made by a qualified maintenance person only.



To minimize the possibility of fire or shock hazards, do not expose this instrument to rain or excessive moisture.



Do not use this instrument in areas under hazardous conditions such as excessive shock, vibration, dirt, moisture, corrosive gases or oil. The ambient temperature of the areas should not exceed the maximum rating specified in Chapter 5.

2 - 1 Unpacking

Upon receipt of the shipment remove the unit from the carton and inspect the unit for shipping damage.

If any damage due to transit, report and claim with the carrier.

Write down the model number, serial number, and date code for future reference when corresponding with our service center. The serial number (S/N) and date code (D/C) are labeled on the box and the housing of the unit.

2 - 2 Mounting

Make panel cutout to dimension shown in Figure 2-1.

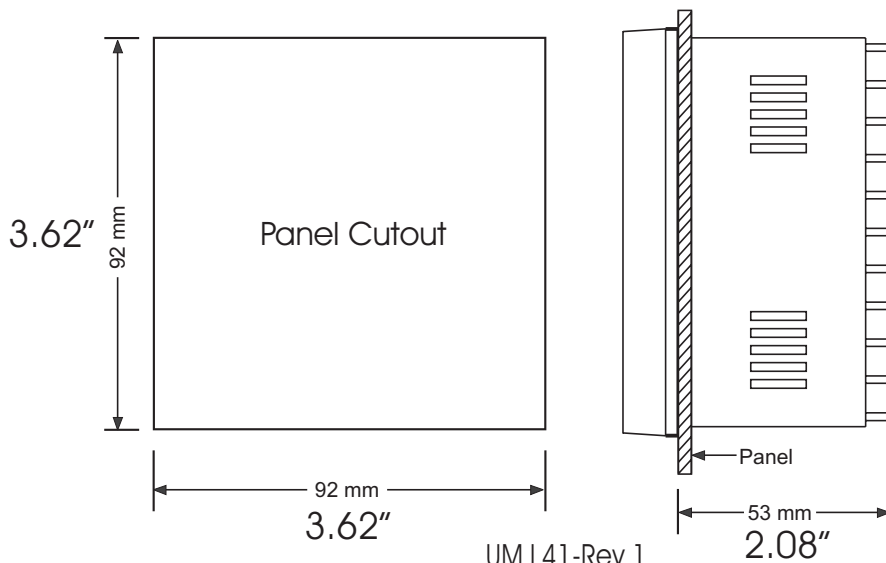

2 - 3 Wiring Precautions

- * Before wiring, verify the label for correct model number and options. Switch off the power when checking.
- * Care must be taken to ensure that maximum voltage rating specified on the label are not exceeded.
- * It is recommended that power of these units to be protected by fuses or circuit breakers rated at the minimum value possible.
- * All units should be installed inside a suitably grounded metal enclosure to prevent live parts being accessible from human hands and metal tools.
- * All wiring must conform to appropriate standards of good practice and local codes and regulations. Wiring must be suitable for maximum voltage, current, and temperature rating of the system.
- * Beware not to over-tighten the terminal screws. The torque should not exceed 1 N-m (8.9 Lb-in or 10.2 KgF-cm).
- * Unused control terminals should not be used as jumper points as they may be internally connected, causing damage to the unit.
- * Verify that the ratings of the output devices and the inputs as specified in Chapter 6 are not exceeded.
- * Except the thermocouple wiring, all wiring should use stranded copper conductor with maximum gauge 18 AWG.
- * To remove the dust please use the dry cloth.
- * Protection impairment if used in a manner not specified by the manufacturer.

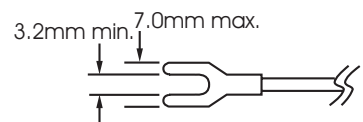
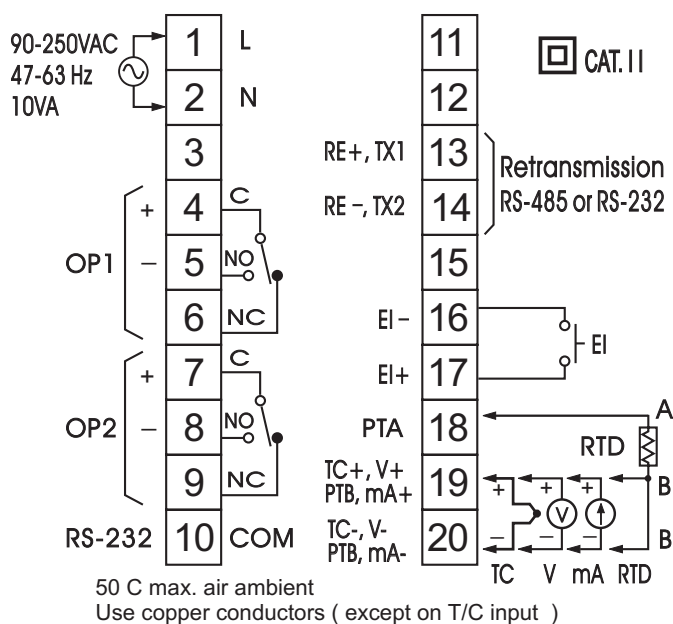

Figure 2-2 Lead Termination

**Figure 2-3
Rear Terminal
Connection Diagram**

2-4 Power Wiring

The controller is supplied to operate at 11-26 VAC / VDC or 90-250 VAC. Check that the installation voltage corresponds with the power rating indicated on the product label before connecting power to the controller. Near the controller a fuse and a switch rated at 2A/250VAC should be equipped as shown in the following diagram.

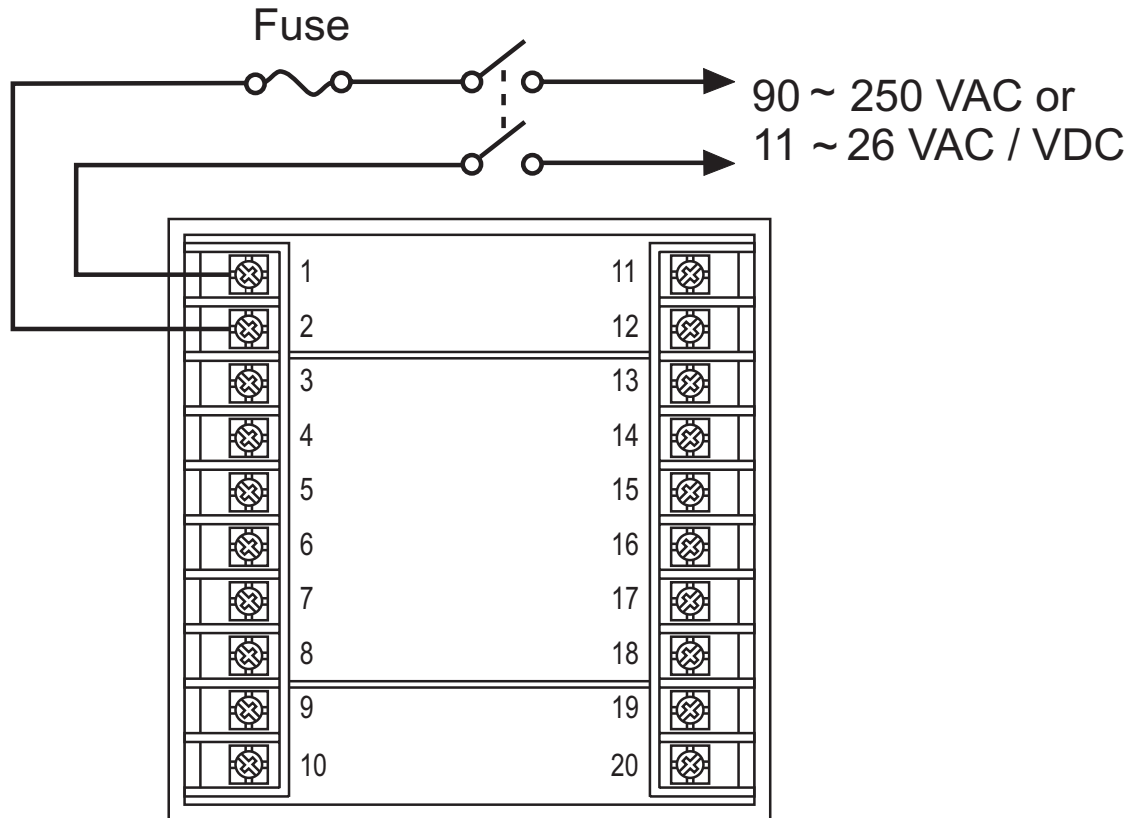

Figure 2-4 Power Supply Connections

 This equipment is designed for installation in an enclosure which provides adequate protection against electric shock. The enclosure must be connected to earth ground.

Local requirements regarding electrical installation should be rigidly observed. Consideration should be given to prevent from unauthorized person access to the power terminals.

2-5 Sensor Installation Guidelines

Proper sensor installation can eliminate many problems in a control system. The probe should be placed so that it can detect any temperature change with minimal thermal lag. In a process that requires fairly constant heat output, the probe should be placed closed to the heater. In a process where the heat demand is variable, the probe should be closed to the work area. Some experiments with probe location are often required to find this optimum position.

In a liquid process, addition of a stirrer will help to eliminate thermal lag. Since the thermocouple is basically a point measuring device, placing more than one thermocouple in parallel will provide an average temperature readout and produce better results in most air heated processes.

Proper sensor type is also a very important factor to obtain precise measurements. The sensor must have the correct temperature range to meet the process requirements. In special processes the sensor might need to have different requirements such as leak-proof, anti-vibration, antiseptic, etc.

Standard thermocouple sensor limits of error are ± 4 degrees F (± 2 degrees C) or 0.75% of sensed temperature (half that for special) plus drift caused by improper protection or an over-temperature occurrence. This error is far greater than controller error and cannot be corrected at the sensor except by proper selection and replacement.

2-6 Thermocouple Input Wiring

Thermocouple input connections are shown in Figure 2-5. The correct type of thermocouple extension lead-wire or compensating cable must be used for the entire distance between the unit and the thermocouple, ensuring that the correct polarity is observed throughout. Splices in the cable should be avoided, if possible.

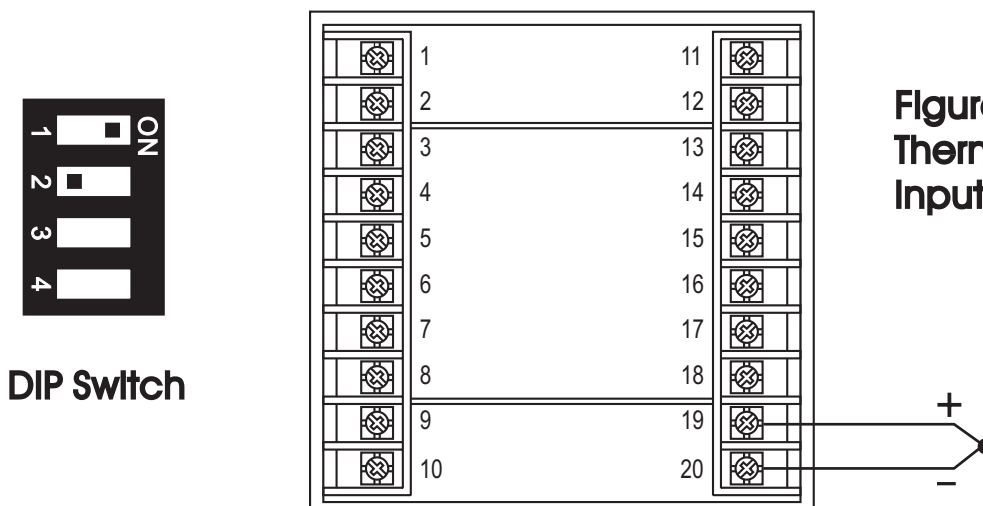

Figure 2-5
Thermocouple
Input Wiring

2-7 RTD Input Wiring

RTD connection are shown in Figure 2-6, with the compensating lead connected to terminal 19. For two-wire RTD inputs, terminals 19 and 20 should be linked. The three-wire RTD offers the capability of lead resistance compensation provided that the three leads are of same gauge and equal length.

Two-wire RTD should be avoided, if possible, for the purpose of accuracy. +/- 0.4 ohm lead resistance of a two-wire RTD will produce 1 degree C temperature error.

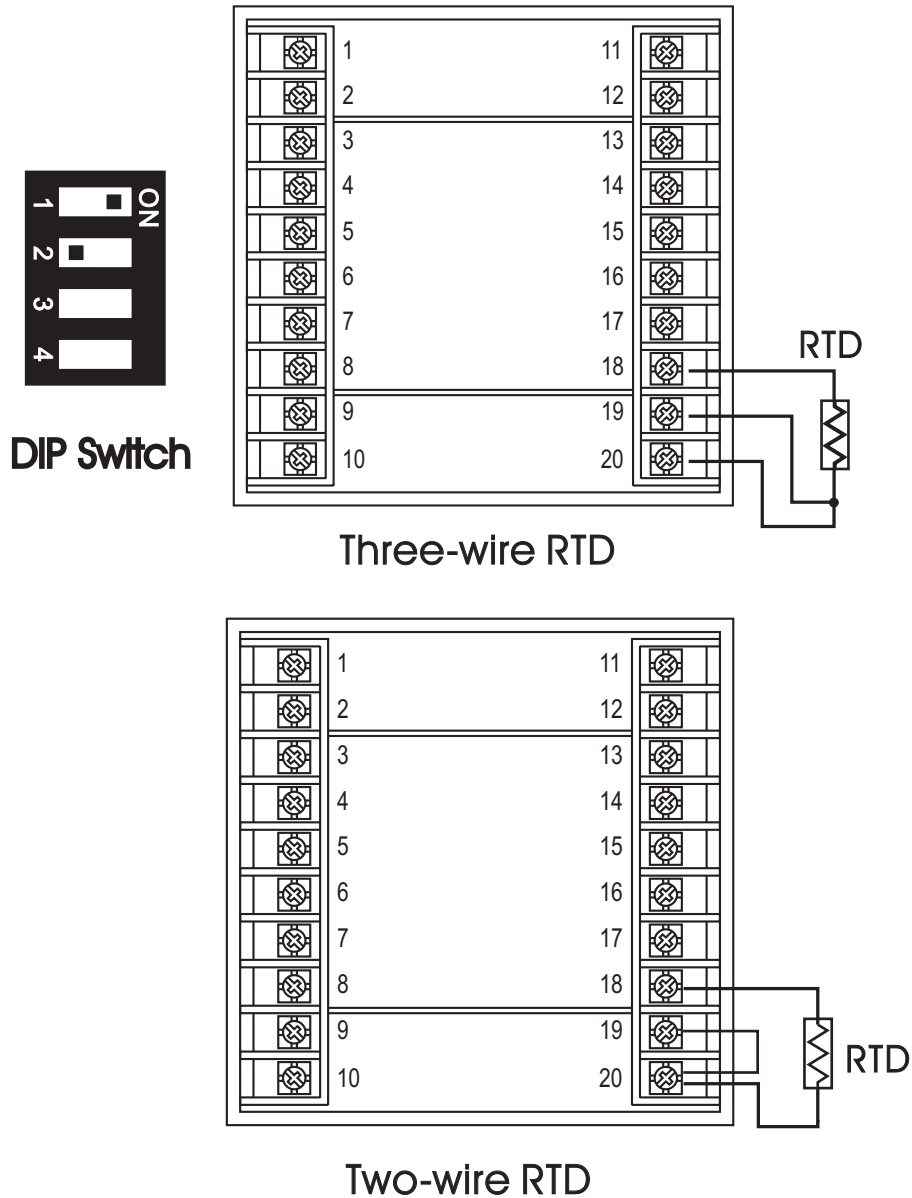

Figure 2-6
RTD Input Wiring

2-8 Linear DC Input wiring

DC linear voltage and linear current connections are shown in Figure 2-7 and 2-8.

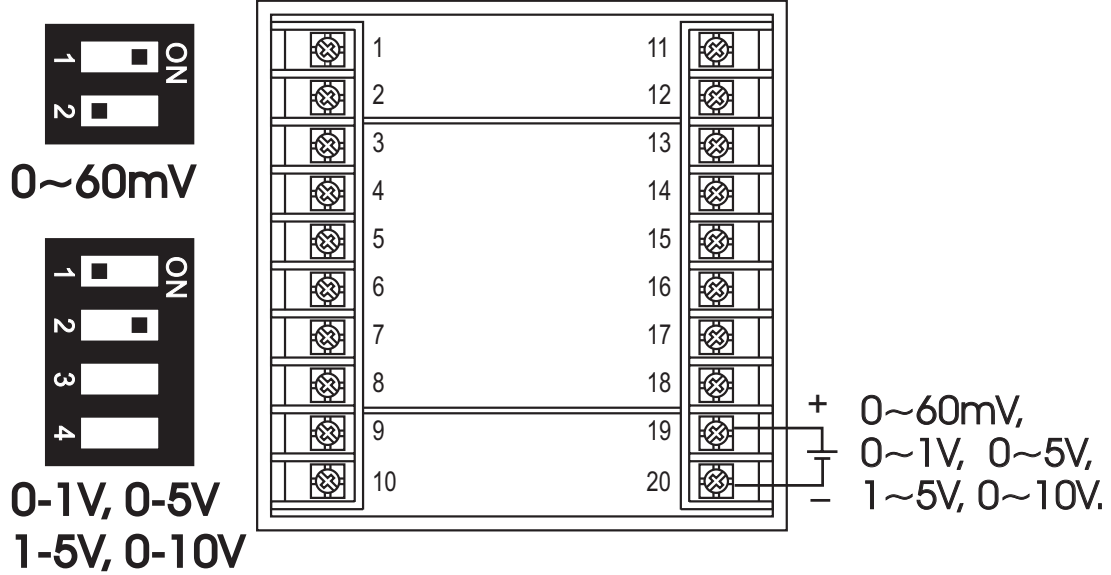

Figure 2-7
Linear Voltage Wiring

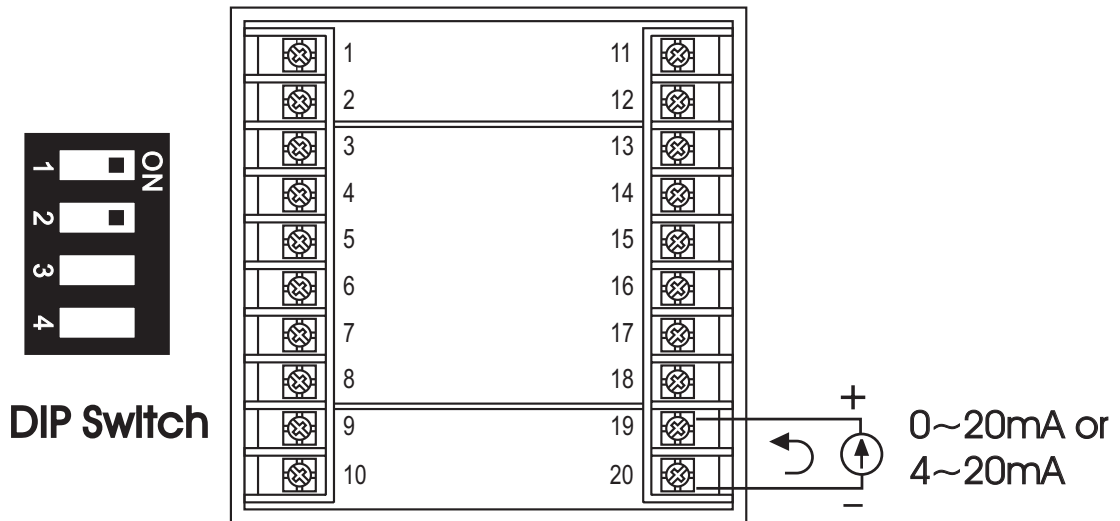

Figure 2-8
Linear Current Wiring

2-9 Event Input wiring

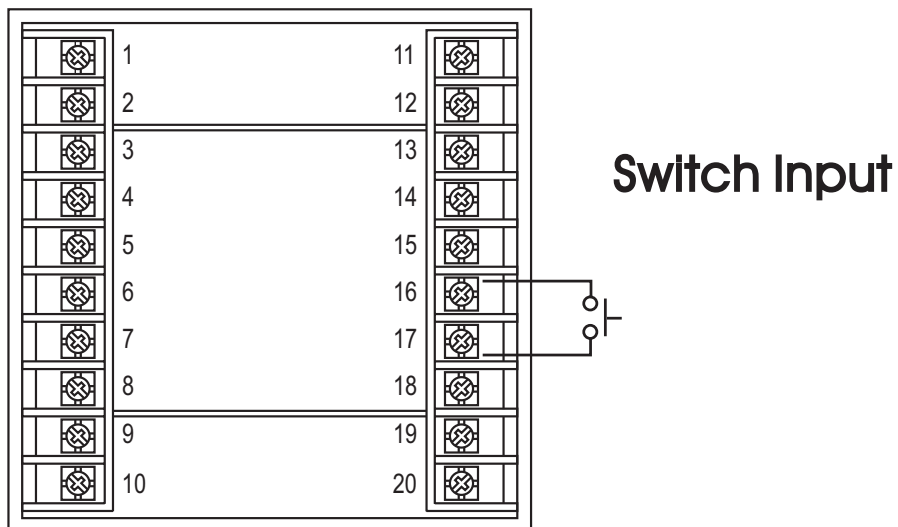
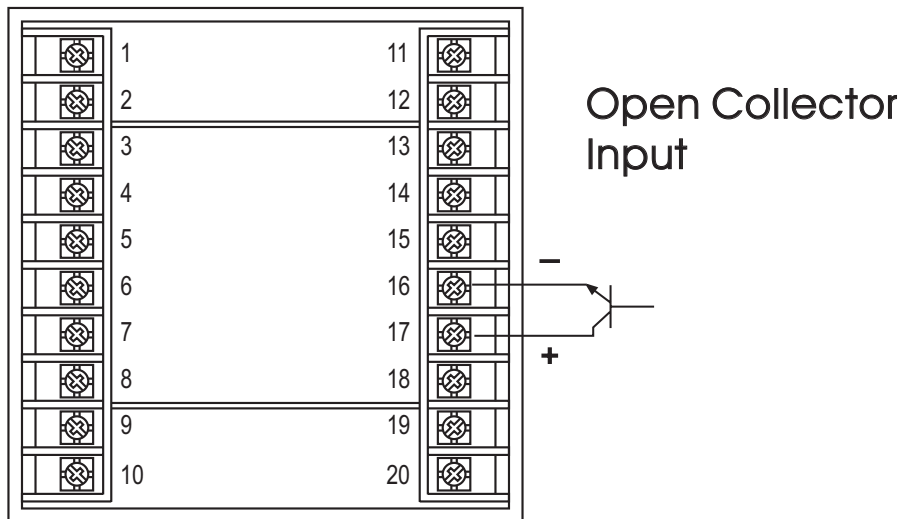

Figure 2-9
Event Input Wiring

The event input can accept a switch signal as well as an open collector signal. The event input function (EIFN) is activated as the switch is closed or an open collector (or a logic signal) is pulled down.

2-10 Output 1 Wiring

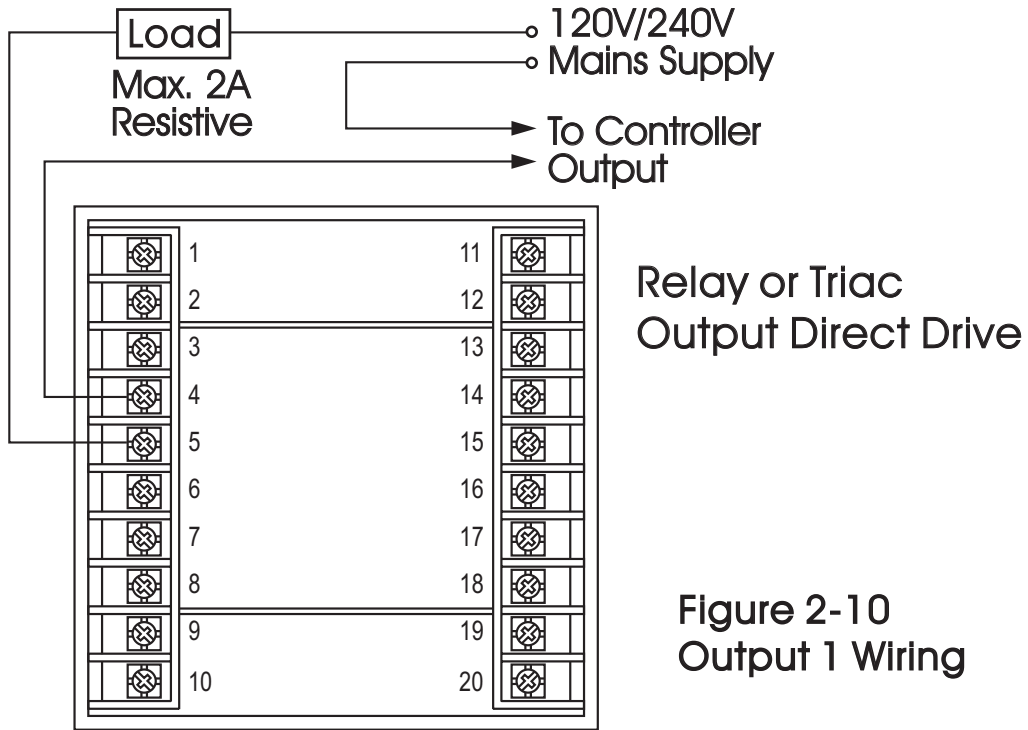
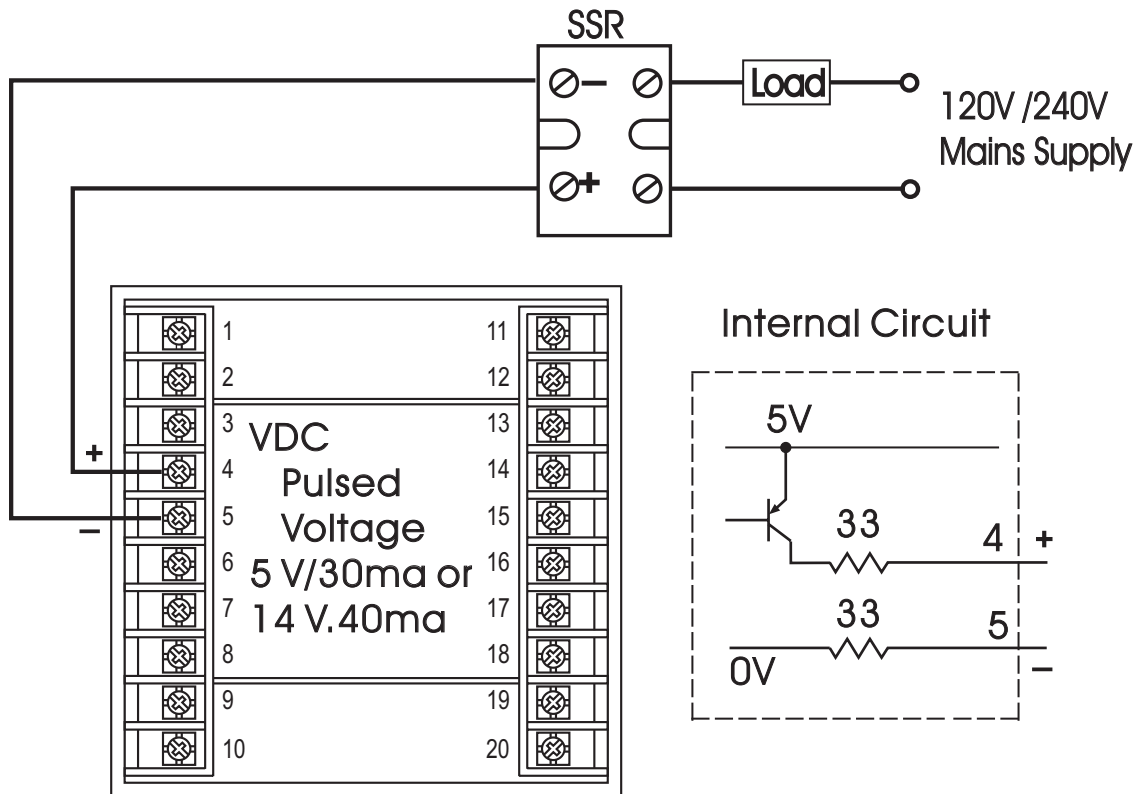

Figure 2-10 Output 1 Wiring



Pulsed Voltage to Drive SSR

2-11 Output 2 Wiring

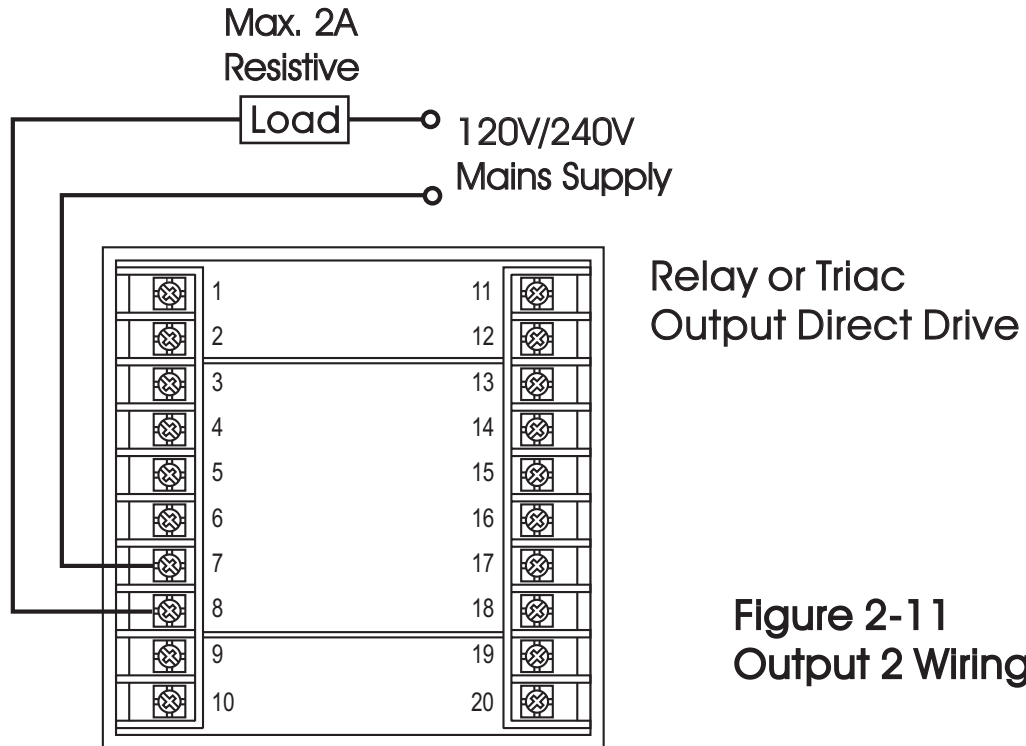
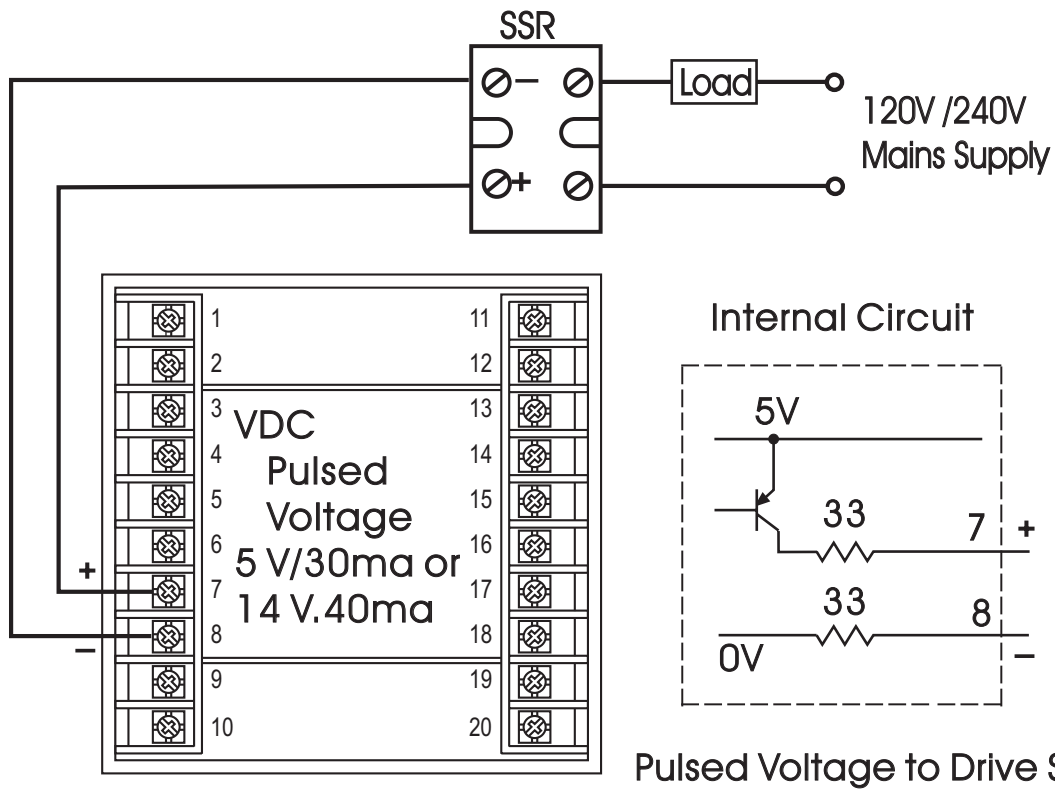

Figure 2-11
Output 2 Wiring



2-12 RS-485

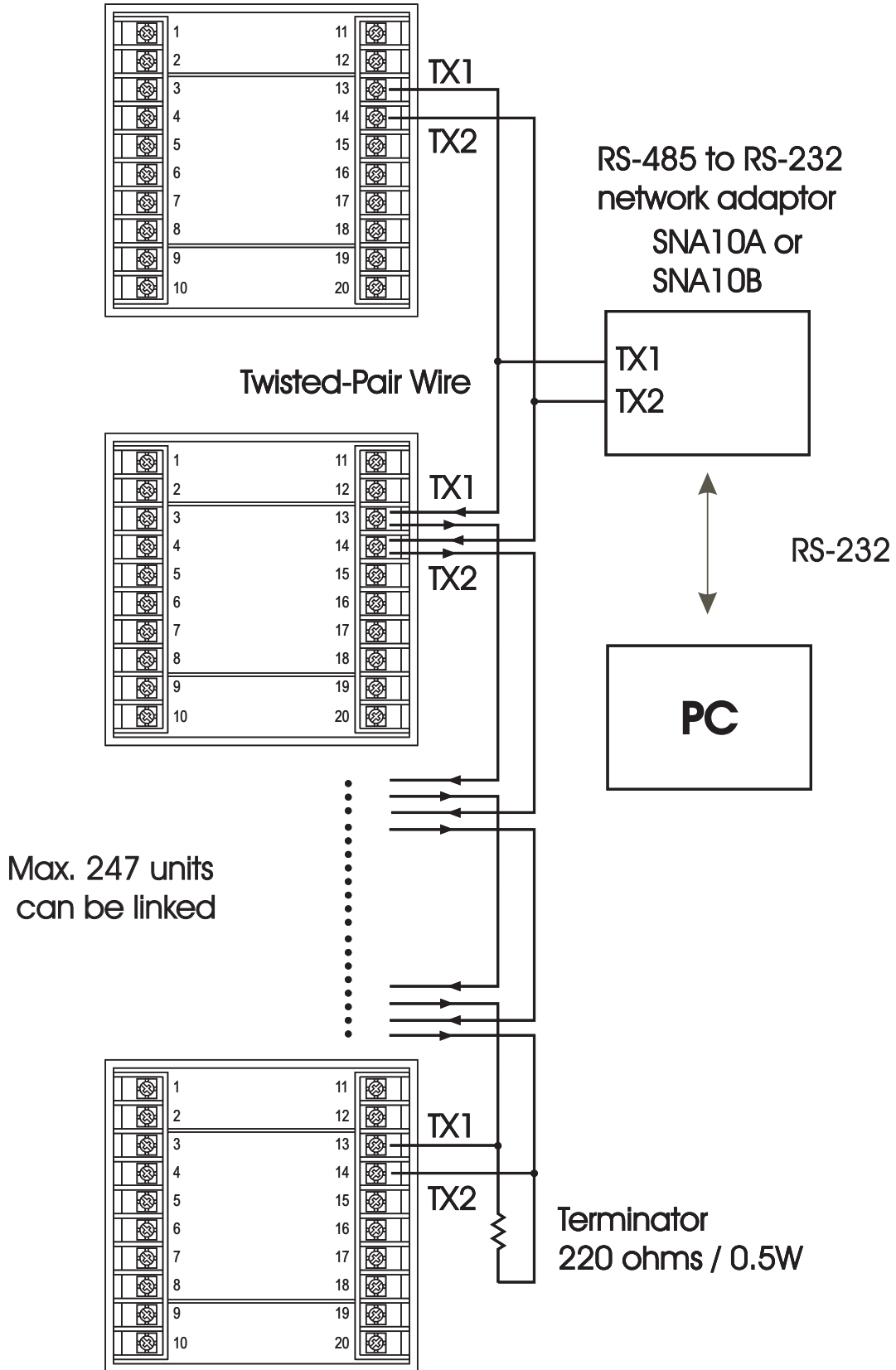
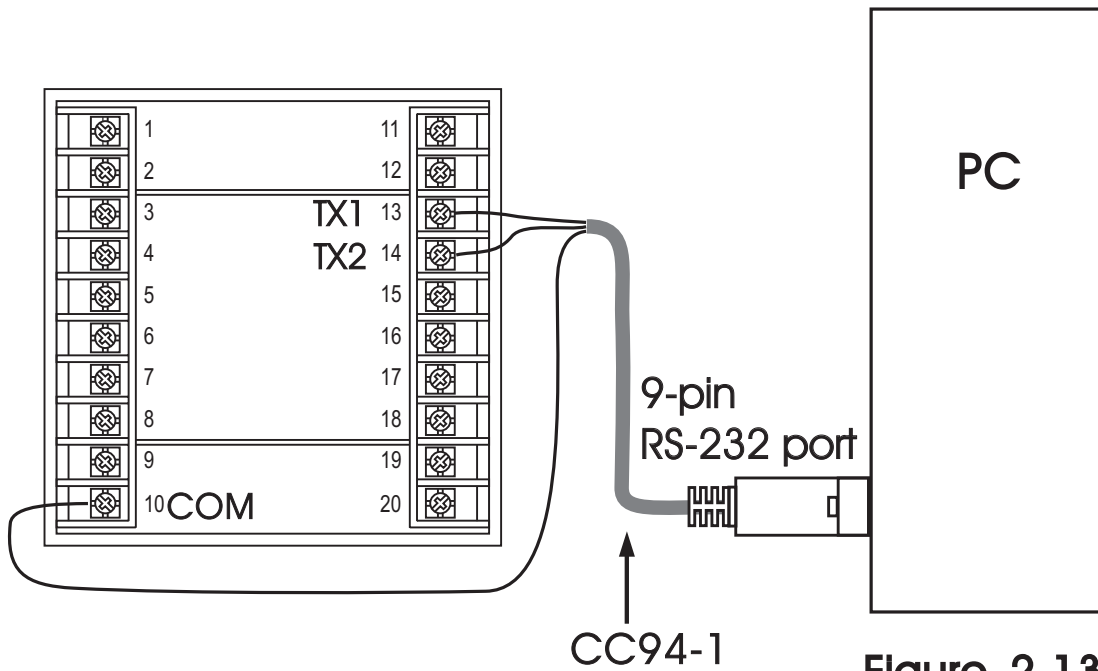

Figure 2.12
RS-485 Wiring

2-13 RS-232



**Figure 2-13
RS-232 Wiring**

If you use a conventional 9-pin RS-232 cable instead of CC94-1, the cable must be modified according to the following circuit diagram.

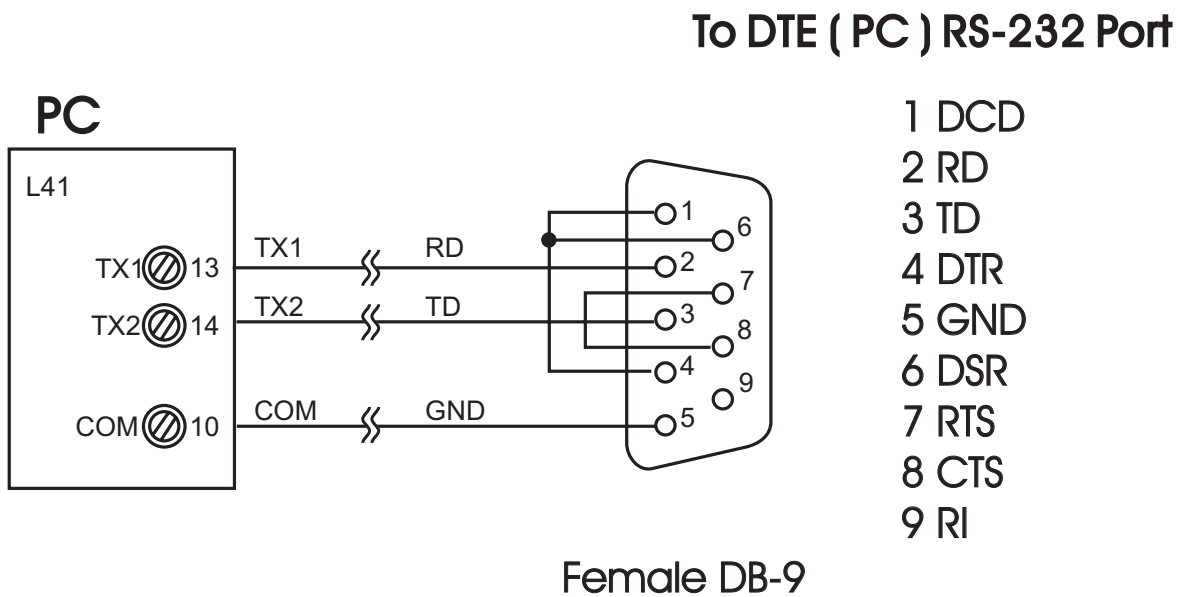

**Figure 2-14
Configuration of RS-232 cable**

2-13 Retransmission

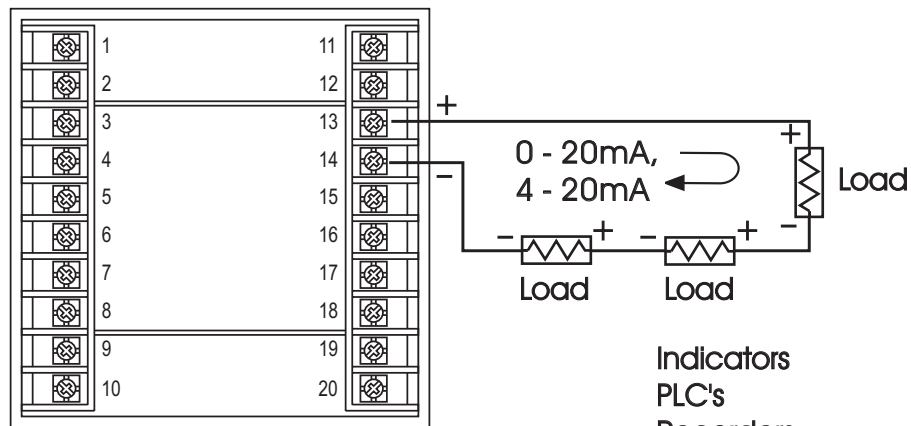

Retransmit Current

The total effective resistance of serial loads can't exceed 500 ohms.

Indicators
PLC's
Recorders
Data loggers
Inverters etc.

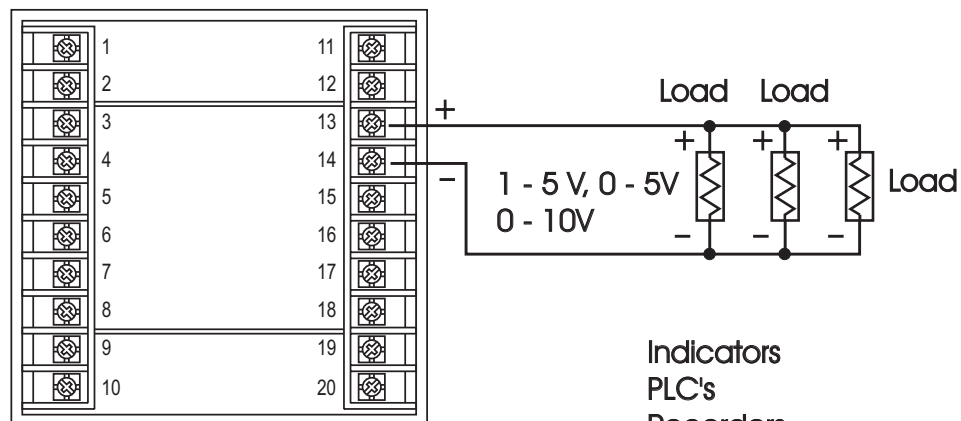

Retransmit Voltage



The total effective resistance of parallel loads should be greater than 10K Ohms.

Indicators
PLC's
Recorders
Data loggers
Inverters etc.

Figure 2-15
Retransmission Wiring

Chapter 3 Programming

3-1 Process Input

Press  for 4 seconds to enter setup mode. Press  to select parameter. The display will indicate the parameter symbol and the value (or selection) for that parameter.

INPT: Selects the sensor type and signal type for the process input.

UNIT: Selects the process unit.

RESO: Selects the location of the decimal point (Resolution) for most (not all) process related parameters.

IN.LO: Selects the low scale value for the Linear type input
Hidden if: T/C or RTD type is selected for INPT

IN.HI: Selects the high scale value for the Linear type input
Hidden if: T/C or RTD type is selected for INPT

How to use IN.LO and IN.HI:

If 4-20mA is selected for INPT, let SL specifies the input signal low (ie. 4mA), SH specifies the signal high (ie. 20mA), S specifies the current input signal value, the conversion curve of the process value is shown as follows:

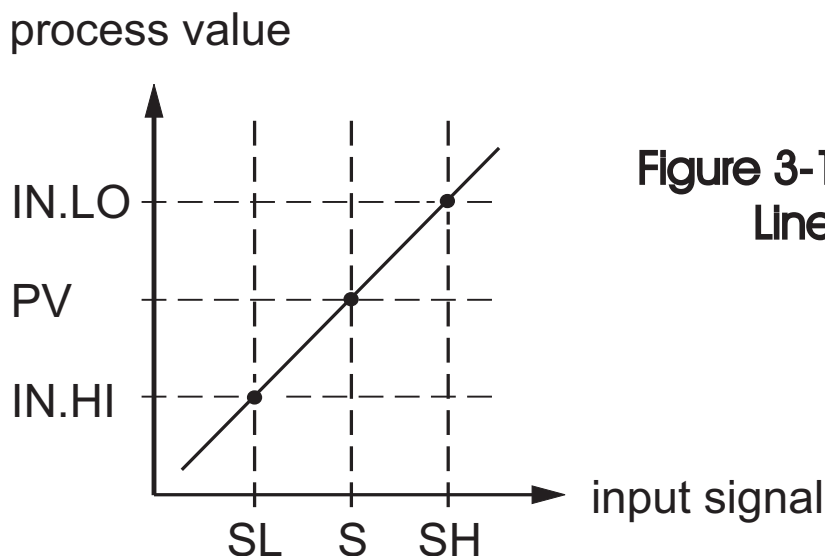

Figure 3-1 Conversion Curve for Linear Type Process Value

$$\text{Formula: } PV = IN.LO + (IN.HI - IN.LO) \frac{S-SL}{SH-SL}$$

Example: a 4-20 mA current loop pressure transducer with range 0 - 15 kg/cm², is connected to input, then perform the following setup:

| | |
|----------------|--------------|
| INPT = 4-20 mA | IN.LO = 0.0 |
| UNIT = PU | IN.HI = 15.0 |
| RESO = 1-DP | |

Of course, you may select other value for RESO to alter the resolution.

3-2 Limit Control

OUT1: Selects the output 1 function. The available output 1 functions are: High Limit Control, Low Limit Control and High/Low Limit Control. Refer to **Section 1-6** for the limit control operation.

O1.HY: Output 1 hysteresis value. The hysteresis value is adjusted to a proper value to eliminate the relay jitter in a noisy environment.

3-3 Set Point Range

HSP.L : Lower limit of HSP1
Hidden if LO is selected for OUT1

HSP.H : Upper limit of HSP1
Hidden if LO is selected for OUT1

LSP.L : Lower limit of LSP1
Hidden if HI is selected for OUT1

LSP.H : Upper limit of LSP1
Hidden if HI is selected for OUT1

HSP.L and HSP.H in setup menu are used to confine the adjustment range of HSP1. LSP.L and LSP.H are used to confine the adjustment range of LSP1.

3-4 PV Shift

In certain application it is desirable to shift the indicated value from its actual value. This can be easily accomplished with this unit by using the PV shift function.

Cycle the unit to the SHIF parameter by using the scroll key. The number you adjust here, either positive or negative, will be added to the actual value. The SHIF function will **alter PV only**.

SHIF: PV shift (offset) value

3-5 Digital Filter

In certain applications the process value is too unstable to be read. To Improve this a programmable low pass filter incorporated in the L41 can be used. This is a first order filter with time constant specified by FILT parameter which is contained in setup menu. The FILT is defaulted to 0.5 sec. before shipping. Adjust FILT to change the time constant from 0 to 60 seconds. 0 second represents no filter is applied to the input signal. The filter is characterized by the following diagram.

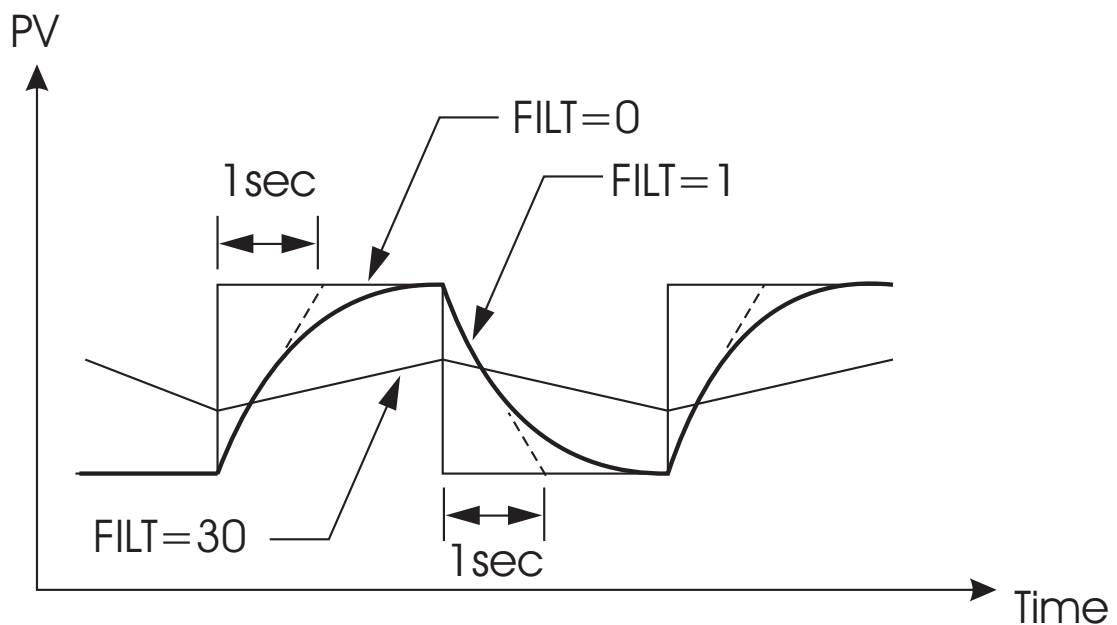

Figure 3-2 Filter Characteristics

3-6 Process Alarms

The output 2 will perform process alarm function and PV.H.A or PV.L.A for AL.FN. If PV.H.A is selected the alarm will perform process high alarm. If PV.L.A is selected the alarm will perform process low alarm. The process alarm sets an absolute trigger level. When the process exceeds that absolute trigger level an alarm occurs. The trigger level is determined by SP2 (Set point 2 value) and AL.HY (Alarm hysteresis value). The hysteresis value is introduced to avoid interference action of alarm in a noisy environment. Normally AL.HY can be set with a minimum value(0.1).

Trigger levels for process high alarm are $SP2 - AL.HY$.
Trigger level for process low alarm are $SP2 + AL.HY$ and $Sp2$.

There are two types of alarm mode can be selected, these are: normal alarm and latching alarm. –

Normal Alarm: AL.MD= NORM

When a normal alarm is selected, the alarm output is de-energized in the non-alarm condition and energized in an alarm condition.

Latching Alarm: AL.MD= LTCH

If a latching alarm is selected, once the alarm output is energized, it will remain unchanged even if the alarm condition has been cleared unless the power is shut off or the RESET key (or remote reset button) is pressed.

Failure Transfer: AL.FT = OFF or ON

In case of **Sensor Break** or **A-D Failure** occurs, the alarm output will be on or off according to the selection of AL.FT.

Examples:

SP2 = 200

AL.HY = 10.0

AL.MD = NORM

AL.FN = PV.H.A

Examples:

Process proceeds →

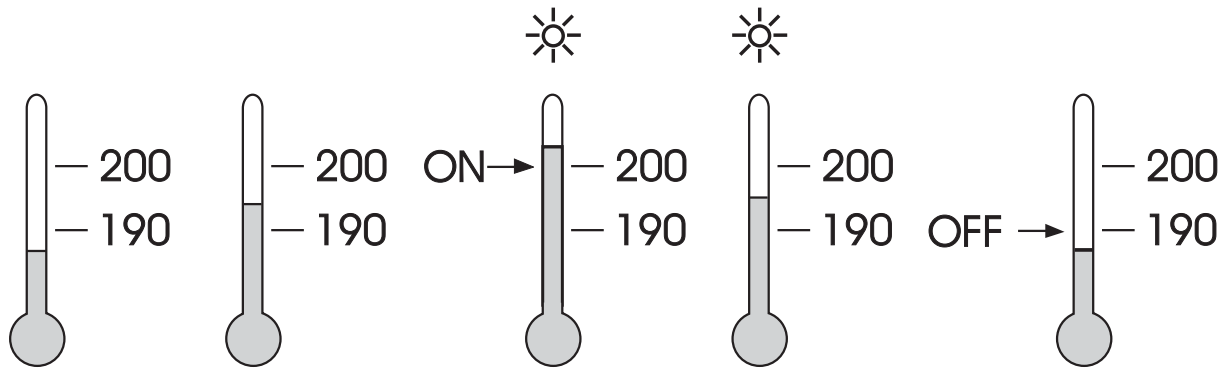

Figure 3-3
Normal Process Alarm

Examples:

SP2 = 200

AL.HY = 10.0

AL.MD = NORM

AL.FN = PV.H.A

SP2 = 200

AL.HY = 10.0

AL.MD = LTCH

AL.FN = PV.H.A

Figure 3-4
Latching Process Alarm

Process proceeds →

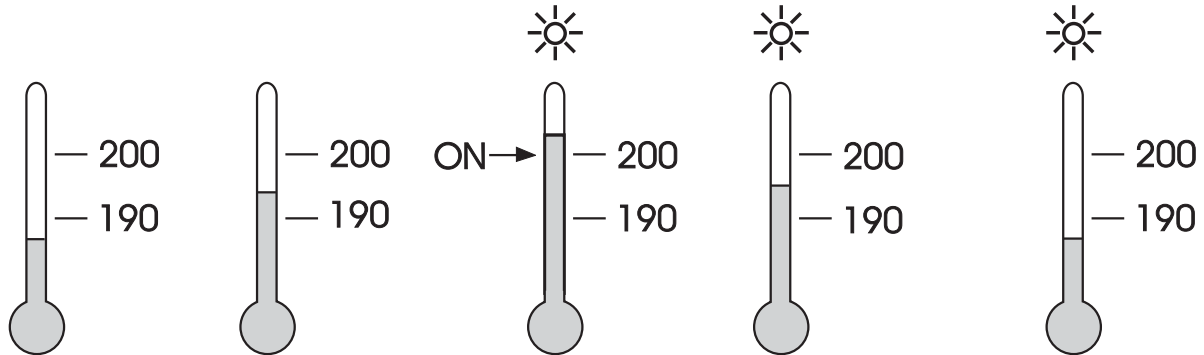

3 - 7 Data Communication

The controllers support **RTU** mode of **Modbus** protocol for the data communication. Other protocols are not available for the series.

Two types of interface are available for Data Communication. These are **RS-485** and **RS-232** interface. Since RS-485 uses a differential architecture to drive and sense signal instead of a single ended architecture which is used for RS-232, RS-485 is less sensitive to the noise and suitable for a longer distance communication. RS-485 can communicate without error over 1 km distance while RS-232 is not recommended for a distance over 20 meters.

Using a PC for data communication is the most economic way. The signal is transmitted and received through the PC communication Port (generally RS-232). Since a standard PC can't support RS-485 port, a network adaptor (such as SNA10A,) has to be used to convert RS-485 to RS-232 for a PC if RS-485 is required for the data communication. Many RS-485 units (up to 247 units) can be connected to one RS-232 port, therefore a PC with 4 comm ports can communicate with 988 units.

Setup

Enters the setup menu.

Select RTU for COMM . Set individual address as for those units which are connected to the same port.

Set the Baud Rate (**BAUD**), Data Bit (**DATA**), Parity Bit (**PARI**) and Stop Bit (**STOP**) such that these values are accordant with PC setup conditions.

If you use a conventional 9-pin RS-232 cable instead of CC94-1, the cable should be modified for proper operation of RS-232 communication according to Section 2-9.

3 -8 PV Retransmission

The controller can output (retransmit) process value via its retransmission terminals RE+ and RE- provided that the retransmission option is ordered. A correct signal type should be selected for COMM parameter to meet the retransmission option installed. AOLO and AOHI are adjusted to specify the low scale and high scale values of retransmission.

3-9 Signal Conditioner DC Power Supply

Typical use of an isolated DC power in unit to external transmitters/sensors is shown.

Options are 20VDC rated at 25mA, 12VDC rated at 40 mA and 5VDC rated at 80 mA. The DC voltage is delivered to the output 2 terminals by selecting DCPS for OUT2 in setup menu.

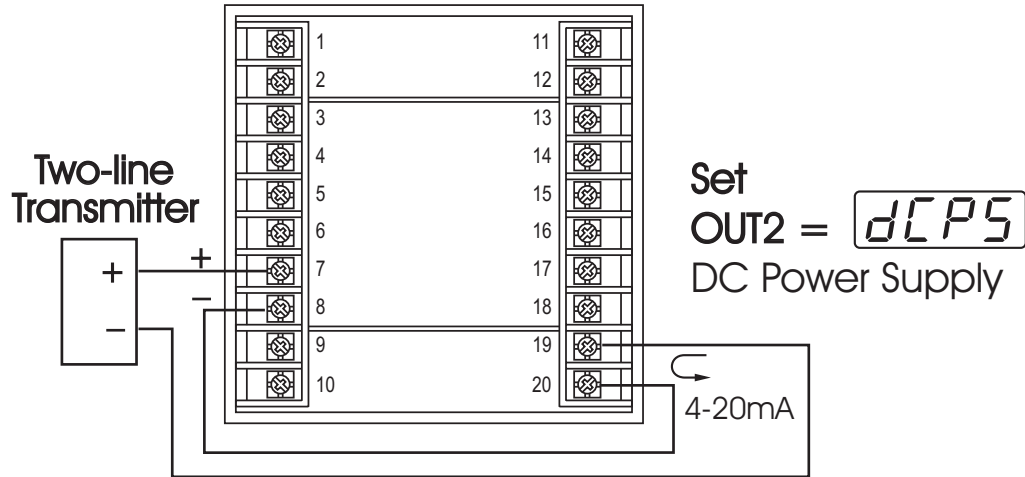

Figure 3-5
DC Power Supply Application

Caution:

Don't use the DC power supply beyond its rating current to avoid damage.
Purchase a correct voltage to suit your external devices. See ordering code in section 1-2.

3-10 Remote Reset

If REST is selected for EIFN, terminals 16 & 17 will act as remote reset input. Pressing remote reset button will perform the same function as pressing the RESET key. Refer to **section 1-4** for RESET key function.

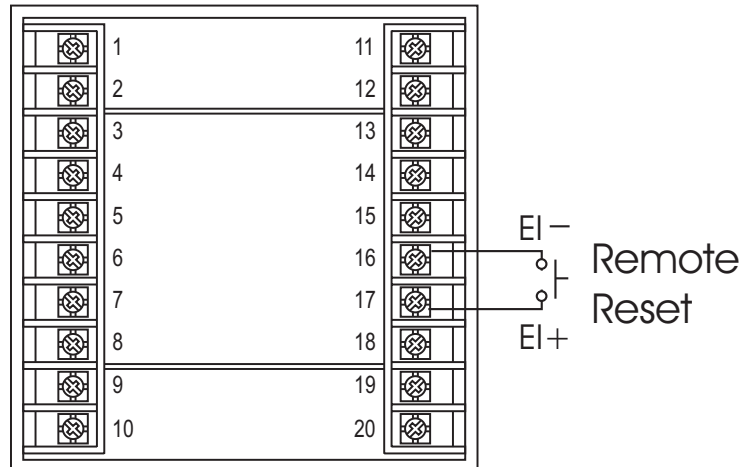

Figure 3-6
Remote Reset Application

3-11 Remote Lock

If LOCK is selected for EIFN, terminals 16 & 17 will act as remote lock input. Turning the remote lock switch on will keep all the parameter setting from been changed. If the switch is opened the lock indicator is extinguished and the up/down key is enabled.

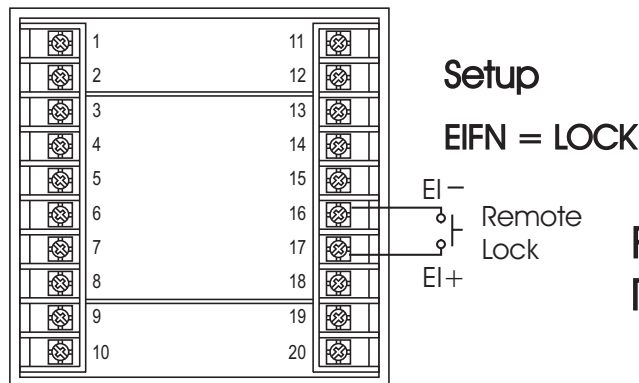

Figure 3-7
Remote Lock

3-12 Limit Annunciator

If L_AN (Limit annunciator) is selected for OUT2, the output 2 will act as a Limit Annunciator. If the limit is or has been reached and the RESET key (or remote reset contacts) has not been pressed since the limit was reached, then the limit annunciator output will be energized and the OP2 indicator will be lit and remain unchanged until the RESET key or remote reset input is applied.

3-13 Reference Data

There are three reference data contained in setup menu. The reference data are read only data. The maximum historical PV, displayed by *P_{UH}*, which shows the maximum process value since the last UNLOCK operation. The minimum historical PV, displayed by *P_{ULO}*, which shows the minimum process value since the last UNLOCK operation. The abnormal time, displayed by *T_{ABN}*, which shows the total accumulated time (minutes) during the process has been in abnormal condition since the last UNLOCK operation.

The values of reference data will be initiated as soon as the RESET key is pressed for 4 seconds (UNLOCK operation). After UNLOCK operation, the PV.HI and PV.LO values will start from the current process value and T.ABN value will start from zero.

3-14 Display Mode

There are three display mode strategies. DISP=SAFE, unit will display the word SAFE in the setpoint display whenever L41 is in a Non-Limit condition. If a Limit condition occurs, SAFE is replaced by the set limit value. Once the limit temperature returns to a Non-Limit condition, SAFE will be displayed again.

Selecting either HSP1 or LSP1 will show the appropriate limit setpoint during all operation of the L41.

Limit process variable is displayed at all times, regardless of DISP selection

Chapter 5 Calibration



Do not proceed through this section unless there is a definite need to re-calibrate the controller. Otherwise, all previous calibration data will be lost. Do not attempt re-calibration unless you have appropriate calibration equipment. If calibration data is lost, you will need to return the unit to your supplier who may charge you a service fee to re-calibrate the unit.



Entering calibration mode will break the control loop. Make sure the system is allowable to apply calibration mode.

Equipments needed for calibration:

- (1) A high accuracy calibrator (Fluke 5520A Calibrator recommended) with following function:
 - 0 - 100 mV millivolt source with +/-0.005 % accuracy
 - 0 - 10 V voltage source with +/-0.005 % accuracy
 - 0 - 20 mA current source with +/-0.005 % accuracy
 - 0 - 300 ohm resistant source with +/-0.005 % accuracy
- (2) A test chamber providing 25 C - 50 C temperature range

Since each unit needs 30 minutes to warm up before calibration procedure is to be performed.

The calibration procedures described in the following are a step by step **manual procedures.**

Press and hold Enter Key (press  for 6 seconds) to enter the calibration mode.

See **figure 4-1.**

Figure 4-1
Flow Chart for Manual Calibration

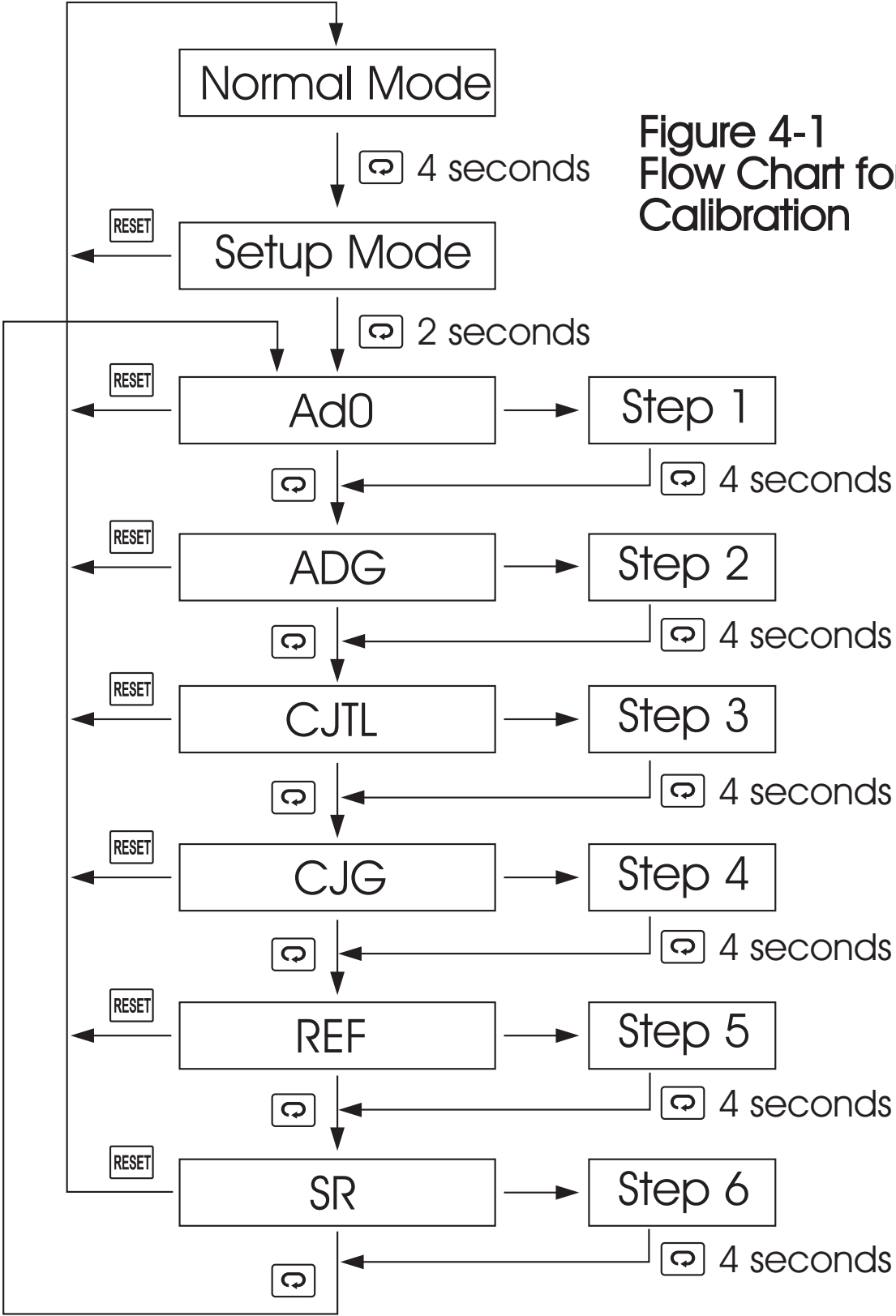

Step1: Calibrate **Zero** of A to D converter. Ad0 Calibration
 Short terminal 4 and 5,
 then press  for at least 4 seconds.
 The display will blink a moment. If the display didn't blink,
 then the calibration fails.
 If calibration fails return to factory.

Step 2: Calibrate **Gain** of A to D converter. ADG Calibration
 Send a span signal to terminal 4 and 5 with correct polarity.
 The span signal is 60 mV for thermocouple input, 1V for
 0-1V input, 10V for 0-10V input and 20mA for 0-20 mA input.
 Press  for at least 4 seconds. The display will blink a
 moment. If the display didn't blink, then the calibration fails.

Step 3: Calibrate **offset** of **cold junction**. CJTL Calibration.
 Setup the equipment according to the following diagram
 for calibrating the cold junction compensation. **Note that a
 K type thermocouple must be used.**

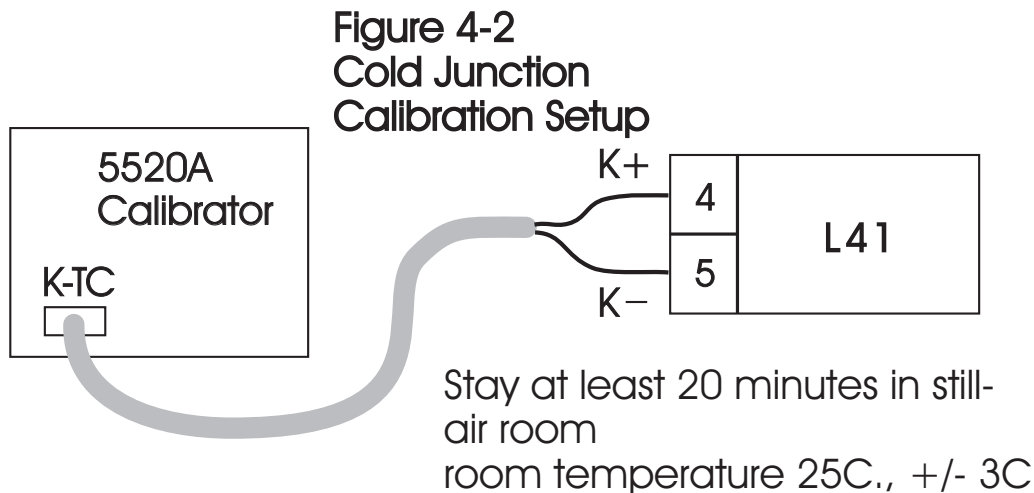

The 5520A calibrator is configured as K. Celsius type thermocouple output with internal compensation. **Send a 0.00 C signal to the unit under calibration.**

The unit under calibration is powered in a still-air room with temperature 25C., +/-3C. Power on unit at least 20 minutes for

Press  for at least 4 seconds. The display will blink a moment. If the display didn't blink, then the calibration fails.
 If calibration fails return to factory.

Step 4: Calibrate **gain** of **cold junction**. CJG Calibration
 This calibration is only needed if unit subjected to 50C ambient.
 Setup the equipment same as step 3. The unit under calibration is powered on in a chamber with still air temperature of 50C +/-3C.
 Power unit at least 20 minutes for warm up. The calibrator source is set to 0.00 C with internal compensation mode.
 Press  for at least 4 seconds. The display will blink a moment. If the display didn't blink, then the calibration fails.
 If calibration fails return to factory.

Step 5: Calibrate **RTD reference voltage**. REF Calibration
 Send a 100 ohms signal to terminal 3, 4 and 5 according to **Figure 5-3**.

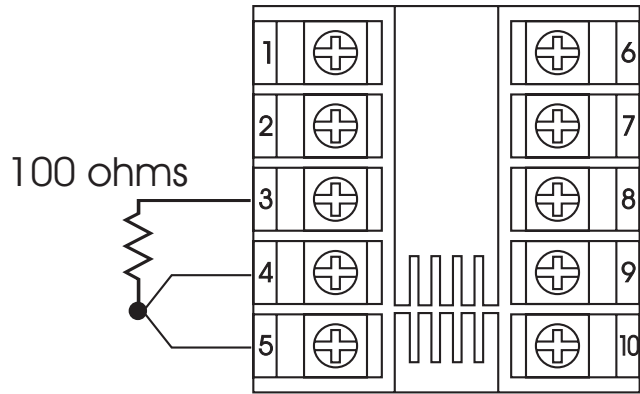



Figure 4-3
RTD Calibration

Press  for at least 4 seconds. The display will blink a moment. If the display didn't blink, then the calibration fails. If calibration fails return to factory.

Step 6: Calibrate **RTD serial resistance**. SR Calibration.

Change the ohm's value of the calibrator to 300 ohms. Press  for at least 4 seconds. The display will blink a moment. If the display didn't blink, then the calibration fails. If calibration fails return to factory.

*** Input modification and re-calibration** procedures for a **linear voltage** or a **linear current** input:

1. Change resistor R62 on the control board with the recommended values specified in the following table.
 The low temperature coefficient resistors with +/-1% +/-50ppm should be used for R62. Adjust the DIP switch according to table 1.1
2. Perform **Step 1** to calibrate the linear input zero.
3. Perform **Step 2** but send a span signal to the input terminals instead of 60mV. The span signal is 1V for 0~1V input, 5V for 0~5V or 1~5V input, 10V for 0~10V input and 20mA for 0~20mA or 4~20mA input.

| Input Function | R62 |
|------------------|------|
| T/C, RTD, 0~60mV | 300K |
| 0 ~ 1 V | 28K |
| 0 ~ 5V, 1 ~ 5V | 150K |
| 0 ~ 10 V | 300K |

Chapter 5 Specifications

Power

90-250 VAC, 47-63 Hz, 10 VA, 5W maximum

11-26 VAC/VDC, 10 VA, 5W maximum

Input

Resolution: 18 bits

Sampling: 5 times/second

Maximum Rating: -2 VDC minimum, 12 VDC maximum
(1 minute for mA input)

Temperature Effect: +/-1.5 $\mu\text{V} / \text{C}$

Sensor Lead Resistance Effect:

T/C: 0.2 $\mu\text{V}/\text{ohm}$

3-wire RTD: 2.6 C/ohm of resistance difference of two leads

2-wire RTD: 2.6 C/ohm of resistance sum of two leads

Burn-out Current: 200nA

Common Mode Rejection Ratio (CMRR): 120db

Sensor Break Detection:

Sensor open for TC, RTD and mV inputs,
below 1 mA for 4-20 mA input,
below 0.25V for 1-5 V input,
unavailable for other inputs.

Sensor Break Responding Time:

Within 4 seconds for TC, RTD and mA inputs,
0.1 second for 4-20 mA and 1-5V inputs.

Event Input

Logic Low: -10V minimum, 0.8V maximum.

Logic High: 2V minimum, 10V maximum.

Functions: Remote reset, remote lockout.

Output 1 / Output 2

Relay Rating: 2A/240 VAC,

life cycles 200,000 for resistive load.

Pulsed Voltage: Source Voltage 5V,

current limiting resistance 66 ohms.

Triac (SSR) Output

Rating: 1A/240 VAC

Inrush Current: 20A for 1 cycle

Min. Load Current: 50 mA rms

Max. Off-state Leakage: 3 mA rms

Max. On-state Voltage: 1.5 V rms

Insulation Resistance: 1000 Mohms min. at 500 VDC

Dielectric Strength: 2500 VAC for 1 minute

DC Voltage Supply Characteristics (Installed at Output 2)

| Type | Tolerance | Max. Output Current | Ripple Voltage | Isolation Barrier |
|------|-----------|---------------------|----------------|-------------------|
| 20 V | +/-1 V | 25 mA | 0.2 Vp-p | 500 VAC |
| 12 V | +/-0.6 V | 40 mA | 0.1 Vp-p | 500 VAC |
| 5 V | +/-0.25 V | 80 mA | 0.05 Vp-p | 500 VAC |

Data Communication

Interface : RS-232 (1 unit), RS-485 (up to 247 units)

Protocol : Modbus Protocol RTU mode

Address : 1 - 247

Baud Rate : 0.3 ~ 38.4 Kbits/sec

Data Bits : 8 bits

Parity Bit : None, Even or Odd

Stop Bit : 1 or 2 bits

Communication Buffer : 50 bytes

Analog Retransmission

Output Signal : 4-20 mA, 0-20 mA, 0 - 5V,
1 - 5V, 0 - 10V

Resolution : 15 bits

Accuracy : +/-0.05 % of span +/-0.0025 % / C

Load Resistance :

0 - 500 ohms (for current output)

10 K ohms minimum (for voltage output)

Output Regulation : 0.01 % for full load change

Output Settling Time : 0.1 sec. (stable to 99.9 %)

Isolation Breakdown Voltage : 1000 VAC min.

Integral Linearity Error : +/-0.005 % of span

Temperature Effect : +/-0.0025 % of span/ C

Saturation Low : 0 mA (or 0V)

Saturation High : 22.2 mA (or 5.55V, 11.1V min.)

Linear Output Range :0-22.2mA(0-20mA or 4-20mA)

0-5.55V (0 - 5V, 1 - 5V)

0 - 11.1 V (0 - 10V)

User Interface

Dual 4-digit LED Displays

Keypad: 4 keys

Programming Port: For automatic configuration.

Communication Port: Connection to PC
for supervisory control.

Limit Control: High Limit, Low limit and High/Low Limit
programmable

Digital Filter

Function: First order

Time Constant: 0, 0.2, 0.5, 1, 2, 5, 10, 20, 30, 60 seconds
programmable

Environmental & Physical

Operating Temperature : -10 C to 50 C
 Storage Temperature : -40 C to 60 C
 Humidity : 0 to 90 % RH (non-condensing)
 Altitude: 2000 m maximum
 Pollution: Degree 2
 Insulation Resistance : 20 Mohms min. (at 500 VDC)
 Dielectric Strength : 2000 VAC, 50/60 Hz for 1 minute
 Vibration Resistance : 10 - 55 Hz, 10 m/s for 2 hours
 Shock Resistance : 200 m/s (20 g)
 Moldings : Flame retardant polycarbonate
 Dimensions: 96 mm(W) X 96 mm(H) X 65 mm(D),
 53 mm depth behind panel
 Weight : 250 grams

Approval Standards

Safety : FM Class 3545
 UL Listed File E197216
 CSA File #209463
 RoHS

Protective Class :

IIP65 for panel with additional option
 IP50 for panel without additional option
 IP20 for terminals and housing with
 protective cover. All indoor use.
 CE EMC EN61326

Table A.1 Error Codes and Corrective Actions

| Error Code | Display Symbol | Error Description | Corrective Action |
|------------|----------------|--|---|
| 10 | <i>Er 10</i> | Communication error: bad function code | Correct the communication software to meet the protocol requirements. |
| 11 | <i>Er 11</i> | Communication error: register address out of range | Don't issue an over-range register address to the slave. |
| 14 | <i>Er 14</i> | Communication error: attempt to write a read-only data or a protected data | Don't write a read-only data or a protected data to the slave. |
| 15 | <i>Er 15</i> | Communication error: write a value which is out of range to a register | Don't write an over-range data to the slave register. |
| 39 | <i>SEnb</i> | Input sensor break, or input current below 1 mA if 4-20 mA is selected, or input voltage below 0.25V if 1 - 5V is selected | Replace input sensor. |
| 40 | <i>AdEr</i> | A to D converter or related component(s) malfunction | Return to factory for repair. |

Characteristics:

| Type | Range | Accuracy @ 25 °C | Input Impedance |
|------------------|---------------------------------------|--------------------------------|--------------------|
| J | -120°C- 1000°C (-184°F - 1832°F) | +/-2 C | 2.2 MΩ |
| K | -200°C- 1370°C (-328°F - 2498°F) | +/-2 C | 2.2 MΩ |
| T | -250°C- 400°C (-418°F - 752 °F) | +/-2 C | 2.2 MΩ |
| E | -100°C- 900°C (-148°F - 1652°F) | +/-2 C | 2.2 MΩ |
| B | 0°C- 1820°C (- 32°F - 3308°F) | +/-2 C (200°C- 1820°C) | 2.2 MΩ |
| R | 0°C- 1767.8°C (- 32°F - 3214°F) | +/-2 C | 2.2 MΩ |
| S | 0°C- 1767.8°C (- 32°F - 3214°F) | +/-2 C | 2.2 MΩ |
| N | -250°C- 1300°C (-418°F - 2372°F) | +/-2 C | 2.2 MΩ |
| L | -200°C- 900°C (-328°F - 1652°F) | +/-2 C | 2.2 MΩ |
| C | 0°C - 2315°C (32°F - 4199°F) | +/-2 C | 2.2 MΩ |
| P | 0°C - 1395°C (32°F - 2543°F) | +/-2 C | 2.2 MΩ |
| PT100 (DIN) | -210°C- 700°C (-346°F - 1292°F) | +/-0.4 C | 1.3 KΩ |
| PT100 (JIS) | -200°C- 600°C (-328°F - 1112°F) | +/-0.4 C | 1.3 KΩ |
| mV | -8mV- 70mV | +/-0.05 % | 2.2 MΩ |
| mA | -3mA- 27mA | +/-0.05 % | 70.5Ω |
| V | -1.3V- 11.5V | +/-0.05 % | 302 KΩ |

Table 5-1 Input Characteristics

Warranty

Future Design Controls products described in this brochure are warranted to be free from functional defects in material and workmanship at the time the products leave Future Design Controls facilities and conform at that time to the specifications set forth in the relevant Future Design Controls manual, data sheets for a period of 3 years after delivery to the first purchaser for use.

There are no expressed or implied Warranties extending beyond the Warranties herein and above set forth.

Limitations

Future Design Controls provides no warranty or representations of any sort regarding the fitness of use or application of its products by the purchaser. Users are responsible for the selection, suitability of the products for their application or use of Future Design Controls products.

Future Design Controls shall not be liable for any damages or losses, whether direct, indirect, incidental, special, consequential or any other damages, costs or expenses excepting only the cost or expense of repair or replacement of Future Design Control products as described in this manual.

Future Design Controls sole responsibility under the warranty, at Future Design Controls option, is limited to replacement or repair, free of charge, or refund of purchase price within the warranty period specified. This warranty does not apply to damage resulting from transportation, alteration, misuse or abuse.

Future Design Controls reserves the right to make changes without notification to purchaser to materials or processing that does not affect any applicable specifications.

Return Material Authorization:

Contact Future Design Controls for Return Material Authorization (RMA) number prior to returning any product to our facility.