



Temperature Controller

N1020



Introduction

The temperature controller **N1020** features advanced performance capability for the most complex and critical applications. Based on a high-end microprocessor and designed with a sophisticated auto-adaptive PID algorithm it continuously adjusts the PID parameters for best controlling performance.

The programmable input, configurable dual output along with the full range power supply provide maximum flexibility in application.

This 1/32 DIN size instrument has extremely small front dimensions of only 48x24 mm or 1/32nd DIN and is the right choice for controlling laboratory equipment when panel space is reduced.

Features and Specifications

- Switching power supply: 100 to 240 Vac and 24 to 240 Vdc
- High brightness red LED display
- Programmable input: thermocouples, Pt100 RTD and 50 mV
- Auto-adaptive PID control
- PID parameters auto-tuning
- Dual output: 1 pulse and 1 relay
- Output functions: control, alarm 1, alarm 2
- Configurable alarms with 8 different functions
- Alarm inhibit function at start up
- Programmable timer
- "F" key with 3 possible functions
- Soft-start function
- Ramp function
- Measured value offset
- Minimum and maximum limits for SP setting
- Minimum and maximum limits for output value
- Access password for configuration protection
- Factory calibration settings restoration feature
- Silicone keypad
- Front pannel: IP65, polycarbonate UL94 V-2
- Enclosure: IP20, polycarbonate UL94 V-2
- SIZE: 25 x 48 x 105 mm
- Aproximate weight: 75 g
- POWER: 100 to 240 Vac ($\pm 10\%$), 50/60 Hz

- 24 to 240 Vdc ($\pm 10\%$)
- Maximum consumption: 9 VA
- AMBIENT CONDITIONS:
 - Operating Temperature: 0 to 50 °C (32 to 122°F)
 - Relative humidity: 80 % max.
- INPUT:
 - Thermocouples, Pt100 and voltage (according to Tabel 01)
 - Internal Resolution: 32767 levels (15 bits)
 - Display Resolution: 12000 levels (from -1999 to 9999)
 - Input sampling rate: up to 55 per second
 - Accuracy: thermocouples J, K, T, E: 0.25 % of span ± 1 °C
 - Accuracy: thermocouples N, R, S, B: 0.25 % of span ± 3 °C
 - Accuracy: Pt100: 0.2 % of span
 - Accuracy: mV: 0.1 %
 - Input impedance: Pt100 and thermocouples: > 10 MOhm
 - Pt100 measurement: 3-wires, (± 0.00385) with cable length compensation, 0.170 mA excitation current
- OUT1: voltage pulse; 5 V / 25 mA / (Zout= 47 Ohms)
- OUT2: SPST relay; 1.5 A / 240 Vac
- ENCLOSURE: IP65, Polycarbonate (PC) UL94 V-0
- CONNECTORS PROTECTION: IP30, ABS+PC UL94 V-0
- Programmable PWM cycle from 0.5 up to 100 seconds
- Operation starts 3 seconds after power up

Accepted Sensors and Maximum Ranges

Type	Features
J	Range: -110 to 950 °C (-166 to 1742 °F)
K	Range: -150 to 1370 °C (-238 to 2498 °F)
T	Range: -160 to 400 °C (-256 to 752 °F)
N	Range: -270 to 1300 °C (-454 to 2372 °F)
R	Range: -50 to 1760 °C (-58 to 3200 °F)
S	Range: -50 to 1760 °C (-58 to 3200 °F)
B	Range: 400 to 1800 °C (752 to 3272 °F)
E	Range: -90 to 730 °C (-130 to 1346 °F)
Pt100	Range: -200 to 850 °C (-328 to 1562 °F)
0-50 mV	Linear. Programmable Indication from -1999 to 9999

Electrical Connections

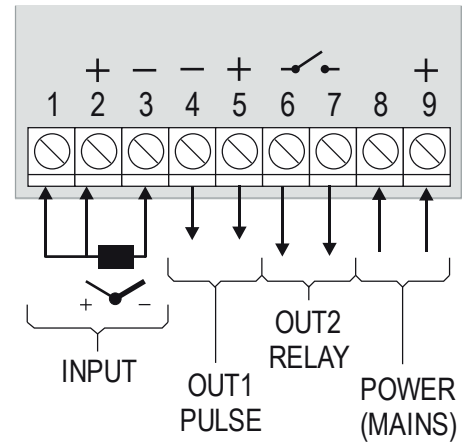

Timer Function

A built-in timer function is available for time down monitoring during control cycles.

The timer **start/stop** options are:

- When PV value reaches control SP value;
- When starting control (RUN= YES);
- Through the “F” key – reset mode: by pressing “F” the timer is automatically zeroed and a new cycle is started;

- Through the “F” key – ON/OFF mode: by pressing “F” the timer halts; by pressing “F” again the timer resumes counting.

Options for **Time Down** function:

- At the end of the time cycle control output (RUN= NO) goes off;

Alarm Functions

Type	Screen	Actuation
Sensor Break (Input Error)	<i>iErr</i>	Goes on with sensor failure/break
Timer On	<i>tOn</i>	Timer On Alarm. Sets the alarm to go on while timer is counting
End of Timer	<i>tEnd</i>	End of timer alarm. Sets the alarm to go on at the end of timer
Minimum Value (Low)	<i>Lo</i>	
Maximum Value (High)	<i>Hi</i>	
Differential	<i>dIF</i>	
Differential Low	<i>dIFL</i>	
Differential High	<i>dIFH</i>	

Alarm Functions

Operation	T1	T2	Actuation
Normal Operation	0	0	
Pulse	1 to 6500 s	0	
Delay	0	1 to 6500 s	
Oscillator	1 to 6500 s	1 to 6500 s	

Timer Alarm Functions



How to Specify

Model	Description	Option 1	Option 2 (Communication)	Option 3 (Power)
N1020	Version with 1 pulse output, 1 SPST relay output, power 100-240 Vac/dc	- USB	- 485	
N1020	Version with 1 pulse output, 1 SPST relay output, power 100-240 Vac / 24-300 Vdc	- USB	- 485	- F