

**Ideal for Hydraulic
Conversion Opportunities**

*Handles Heavy Loads in
Harsh Environments*



Electrak[®] XD

Heavy Duty Smart Electric Linear Actuator
Designed for the Toughest Applications

ANDERSON CONTROLS INCORPORATED

+1 303-692-0290

andersoncontrol.com

THOMSON[®]

Linear Motion. Optimized.[™]

A REGAL REXNORD BRAND



Electrak® XD – The Next Evolution of Electric Actuators

Electric linear actuators have come a long way since their origin as basic, slow, medium load pushing-and-pulling devices more than a half century ago. Protection against the elements has greatly improved, integrated controls have added intelligence to their functionality, and life, reliability and performance have all steadily improved. With Electrak XD, electric linear actuators have taken an evolutionary leap as this model has ushered actuation technology into a realm once ruled by hydraulic systems.

A Jack of All Trades

Electrak XD is the strongest electric linear actuator Thomson has ever built. It is strong enough to take on hydraulic applications while, at the same time, be smarter, smaller and more efficient than competitive technologies.

- Dynamic/static loads up to 25/32 kN
- Strokes up to 1200 mm
- Speeds up to 75 mm/s
- Duty cycle up to 100%
- Life up to 275,000 cycles

Designed for Hydraulic Conversion

Strength alone doesn't always make a linear actuator an ideal candidate for hydraulic conversion. Electrak XD features a unique set of innovations and functionalities that make it not only an obvious choice for conversions but a solution that delivers a host of additional benefits.

- Internal load holding brake - no drift
- Optional shock load dampening feature
- Manual override in case of power failure
- Constant monitoring and diagnostics
- Increased controllability due to onboard controls
- Exact speed, position and force control
- Reduced overall system weight, size and energy consumption



Max. load: 25000 N	Max. speed: 75 mm/s
Max. stroke: 1200 mm	IP rating: IP67/69K
Supply voltages: 24, 48 Vdc	
Temperature: -40°C (-40°F) to +85°C (+185°F)	

Built to Withstand the Elements

Much like our other Electrak actuators, XD offers extensive protection against even the hardest conditions and ingress.

- IP69K (static), IP67 (static) and IP66 (dynamic)
- Operating temperature from -40°C to +85°C (-40°F to +185°F)
- 500 hours salt spray test
- E-coat
- CE, UKCA, RoHS and REACH (EU) compliant

Enhanced Controllability and Diagnostics

Standard and optional onboard controls offer a wide range of smart functions:

- Low level switching as standard
- Speed control as standard
- Force feedback
- Programmable software end-of-stroke limits
- Position feedback
- Bus systems (CANopen® or SAE J1939)

**ELECTRAK
HD**



16000 N	71 mm/s
1000 mm	IP67/69K
12, 24, 48 Vdc	
-40°C (-40°F) to +85°C (+185°F)	

**ELECTRAK
LL**



6000 N	30 mm/s
500 mm	IP66/69K
24 Vdc	
-40°C (-40°F) to +85°C (+185°F)	

**ELECTRAK
MD**



2000 N	53 mm/s
300 mm	IP67/69K
12, 24 Vdc	
-40°C (-40°F) to +85°C (+185°F)	



Safe, Clean and Green Hydraulic Conversion

Going from a hydraulic to electric solution results in a system using less energy, a smaller footprint and reduced complexity. Electric actuators also eliminate all maintenance, waste, hazards, and other nuisances related to hydraulic oil replacement, and potential leaks and spills.

Clean, Energy-Efficient Operation

Running the Electrak XD using electricity rather than a hydraulic pump inherently saves a significant amount of energy. Electricity doesn't require any amount of built-up or reserved pressure and, instead, reacts instantly, helping reduce energy inputs. The weight and size of a hydraulic pump with its oil, pipes, hoses and valves are also eliminated, ultimately lowering the fuel required to move vehicles. Lastly, not having to deal with the unpleasant smells, messes and dangers associated with hydraulic oil is an immeasurable benefit.

Long, Maintenance-Free Life

Electrak XD actuators do not require maintenance throughout their lives, and include few breakable components, ensuring long, trouble-free operation. In the event of service being required to your actuator, a replacement is quickly provided. Oftentimes, all that is needed is to disconnect the cable, remove the front and rear adapter pins, install the new actuator, and resume operations. Conversely, a hydraulic system requires regular maintenance, and even with frequent service, oil leaks occur and dirt builds up. However, the main problem with hydraulics is the system complexity and the dire effects of a breakdown. Hydraulic systems contain such a large number of components that the likelihood of one breaking at any given time is high, and replacing or repairing it requires longer, dirtier and more dangerous work.



Go electric and save significant amounts of energy and cost.

Shock Load Dampening

Due to the viscosity of the oil used, hydraulic cylinders inherently have shock load dampening properties. This feature is beneficial as it can reduce the stress on other components in the system. The Electrak XD's optional shock load dampening feature provides the same benefit and prolongs the life of both the actuator and the entire machine.

Manual Brake Release and Override

When unexpected circumstances, such as power failures, occur, the Electrak XD allows you to literally take matters into your own hands. With the manual brake release and override option, loads can be released and then cranked by hand to any position where an action needs to be performed.





Electrak[®] XD vs. Hydraulic Systems

An Electrak XD electric actuator and a switch will basically replace an entire hydraulic system – cylinder, pipes, valves, pumps and oil reservoirs – saving your machine both space and weight. With onboard controls, the XD is easier to control, allowing you to perform tasks that are difficult to near impossible with a hydraulic system.

Go electric to reduce complexity and the overall system footprint while getting:

- Smarter actuation
- Shock load resistance
- Maintenance- and mess-free operation
- Reduced energy costs
- A greener solution
- Manual brake release and override capability
- Cleaner, safer and weatherproof operation

Onboard Controls

The Electrak XD offers a comprehensive suite of onboard controls to help you advance communication amongst your machines as well as operators.

Standard features:

- Low-level switching
- Speed control

Optional:

- Programmable software end-of-stroke limits
- Force feedback
- Position feedback
- Bus systems (CANopen[®] or SAE J1939)

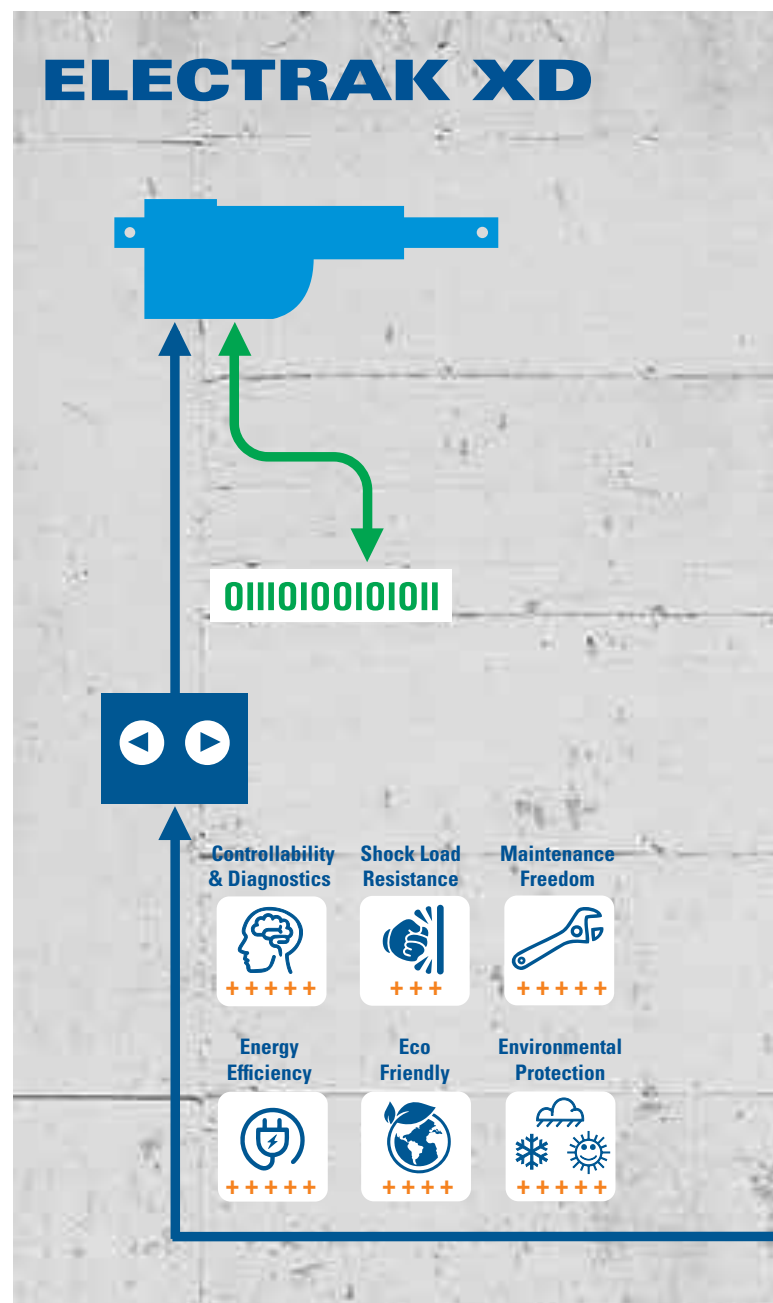

Be Green

Converting from hydraulic to electric not only results in a more efficient system but helps keep the world green by:

- Reducing energy consumption
- Using a cleaner, leakproof system
- Eliminating maintenance and oil replacements
- Making processes leaner

Increased Design Freedom

By going electric, you eliminate a large number of components while avoiding the oil, grease and dirt related to hydraulics. This allows a more flexible design process focused on aesthetics, ergonomics and usability.

HYDRAULIC

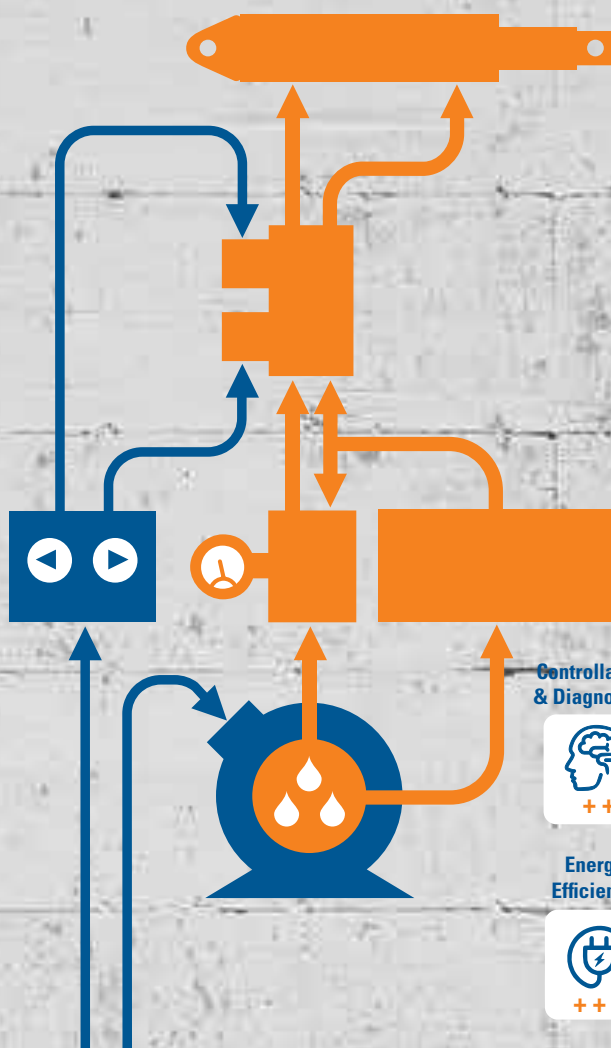

Get clean and green by switching to electric actuators.

Controllability
& Diagnostics



Shock Load
Resistance



Maintenance
Freedom



Energy
Efficiency



Eco
Friendly



Environmental
Protection





Work Smarter, Not Harder

There is no doubt that Electrak® XD exhibits extraordinary strength in load handling, but its intelligence is what sets it apart from the competition. Its onboard controls can turn a seemingly complex task or entire application into a simple one. With controls such as speed control, force feedback and CAN bus, you have a full suite of tools to streamline your automation.

Onboard controls reduce the overall footprint of the Electrak XD and eliminate much of the guesswork associated with integrating it within an automated network. Instead of spending valuable time wiring, installing and testing, you can immediately take advantage of this actuator's plug-and-play control functionalities. Running diagnostics and statistics helps keep productivity and quality up since adjustments can be made in real time without delays.

CAN Bus Controls

CANopen® or SAE J1939 CAN bus let you access most of what is under the hood of the Electrak XD. Run diagnostics on the actuator, read statistics, set parameters, and measure voltage, position, current, force and temperature. These controls also allow you to operate multiple actuators on the same bus remotely from a computer or PLC, controlling their speed, position, force and status simultaneously.

Low-Level Switching

A tiny, two-position switch is all it takes to make Electrak XD go back and forth. No need for huge power switches or relays to handle the motor current.

Speed Control

Optimize the task performed by using the exact speed you need wherever necessary along the

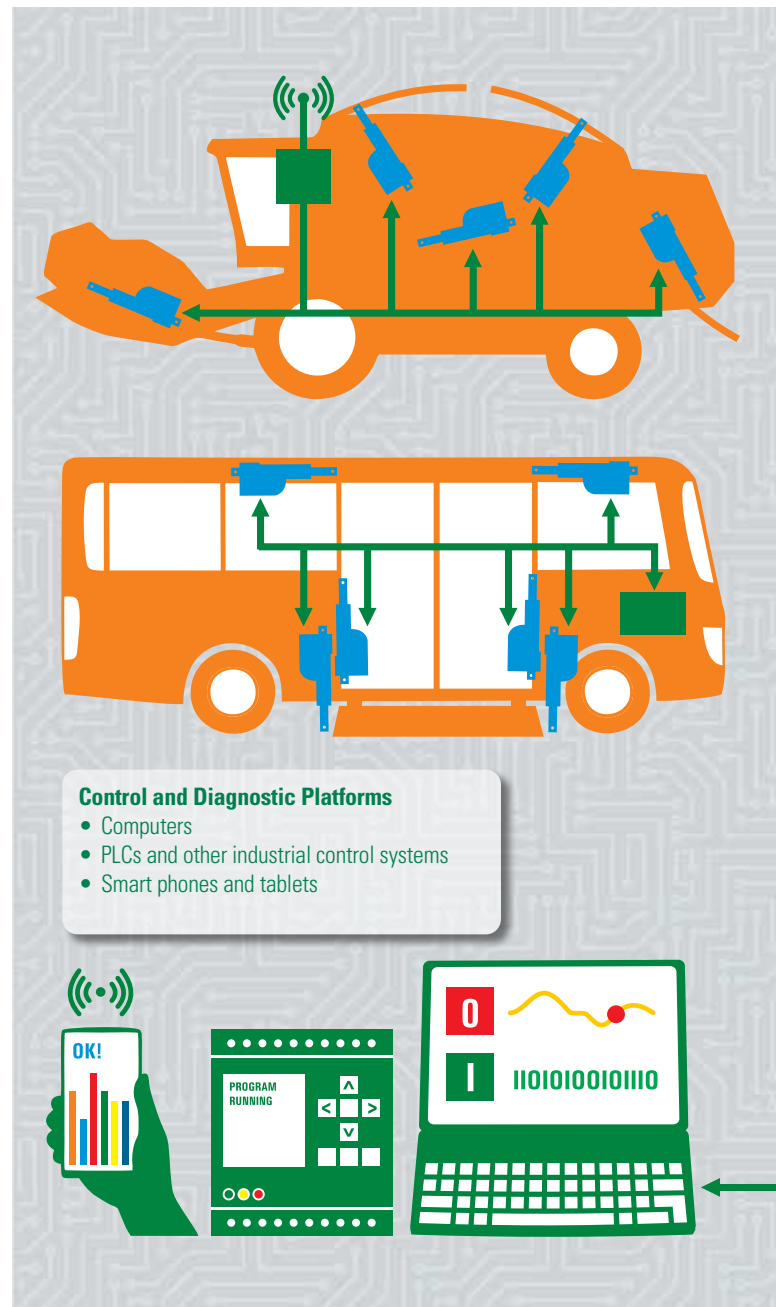

stroke. Speed adjustment also makes it easier to integrate the Electrak XD into systems featuring synchronized components.

Force Feedback

The ability to measure the extension tube force in real time opens up a lot of possibilities. Sorting, probing, tension control and weighing are just a few.

Position Feedback

The absolute type of position feedback device in the Electrak XD gives you the extension tube's exact position and does not require any homing or reset sequence after powering down.

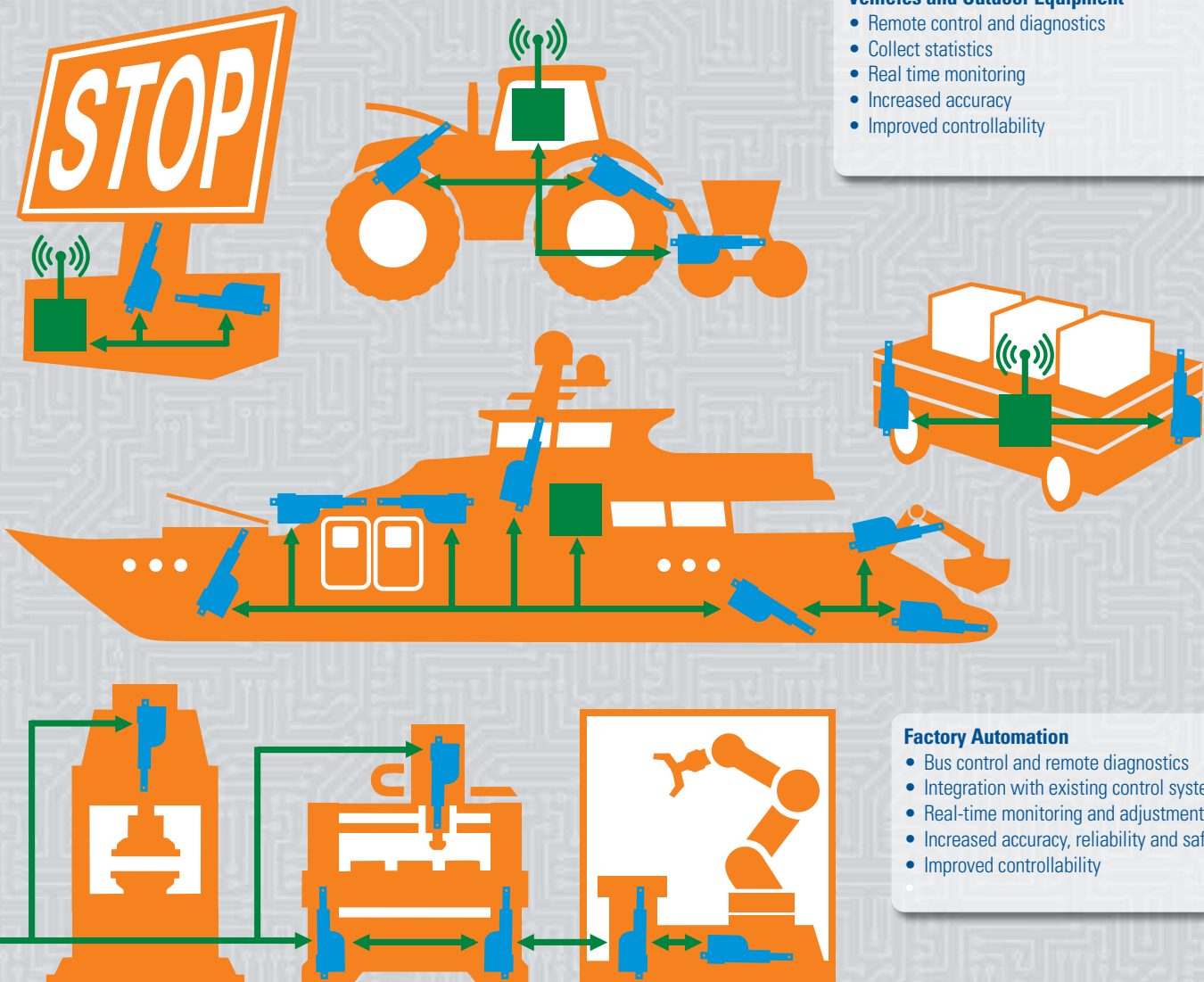



What Makes the Powerful Electrak® XD Tick?

A lot of engineering, experience and dedication is the simple answer. Understanding that every tiny detail matters also helps. Following decades of working closely with customers in their factories, laboratories and fields to learn more about their requirements, Thomson engineers can attest that Electrak XD is, without a doubt, the most heavy duty and versatile electric linear actuator we have produced to date.

MORE POWER

Outstanding power-to-size ratio utilizing state-of-the-art technologies.

- 1 **Brushless DC motor with electromagnetic brake**
- 2 **High-efficiency ball screw and nut**
- 3 **Strong, sturdy and effective gear transmission**
- 4 **Durable, lightweight housing and cover tube in zinc/aluminum**
- 5 **Extension tube in high-quality stainless steel**



BETTER CONTROLLABILITY AND DIAGNOSTICS

Comprehensive onboard control range enabling complex tasks to be operated and monitored.

- 6 **Electronic Monitoring Package with low-level switching and speed control as standard**
- 7 **Six additional control options**

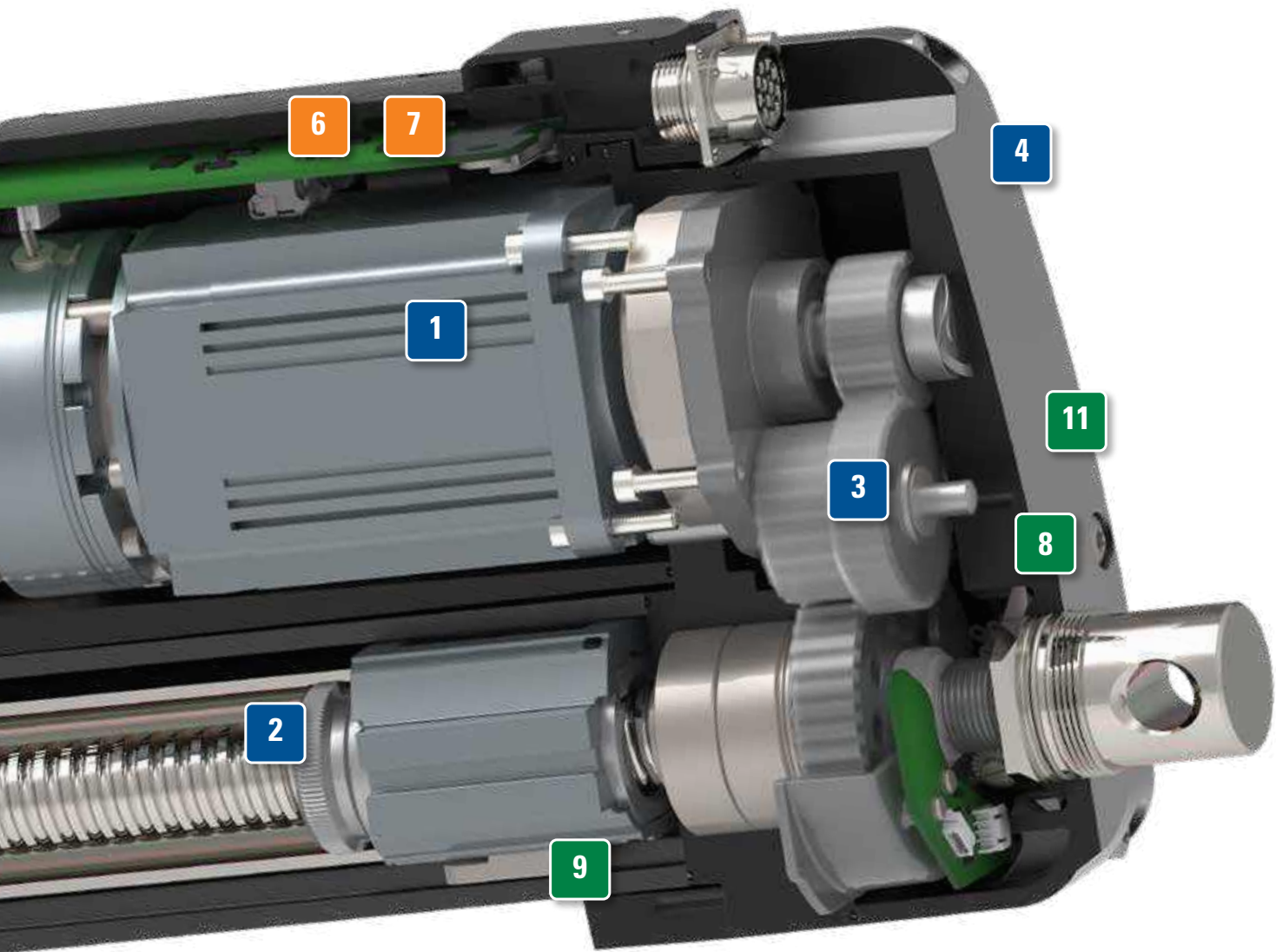

SUPERB RELIABILITY AND ENVIRONMENTAL PROTECTION

Ready whenever and wherever without ever requiring maintenance or service.

- 8** Completely sealed
- 9** IP66 / IP67 / IP69K
- 10** Stainless steel extension tube and hardware
- 11** E-Coating
- 12** Built and tested according to the toughest standards and specifications



Manual Brake Release and Override

In situations where a machine component is stuck, breaks or finds itself in an awkward position, the Electrak® XD can be moved manually into a position that allows the user access for maintenance. This manual brake release option disengages the holding brake so that the extension tube can be manually cranked to the desired position.

Manual Brake Release

The manual brake release lever allows the Electrak XD to travel under the power of applied load and/or gravity. When utilizing the manual brake release, it is important to keep the actuator connected to power as the motor will act as a generator to send power back to your supply. This regen capability helps control the movement of the XD when the manual brake release lever is used.

Manual Override

The manual override option allows the user to manually drive the actuator to a full extend-and-retract cycle under maximum loading to achieve movement where power may not be available. This capability comes in handy for machine maintenance or installation.



Manual Override Input

Remove the protective cover to access the hexagonal override shaft input head, which can be cranked with a hex wrench.

Manual Brake Release Lever

When pulling the brake release lever, the brake will disengage, and the extension tube and load will be free to move in any direction.

Shock Load Dampening

A key benefit of hydraulic cylinders has always been their inherent ability to withstand shock loads, which stems from the viscosity of their oil. However, in a groundbreaking achievement of engineering, the Electrak XD is now the first electric linear actuator available with an optional shock load dampening feature.

Load dampening is a unique option that utilizes a design in the rear adapter to handle shock load scenarios over the life of the actuator. This feature allows the Electrak XD to be utilized in more applications that would typically require hydraulic systems.

How Does it Work?

The rear adapter adds a set of shock-absorbing washers that will elastically deform and dissipate energy in the load path of the actuator. In this way, both positive and negative shock loads are prevented from acting on the other mechanical components of the thrust assembly, including the ball nut, ball screw and thrust bearings.

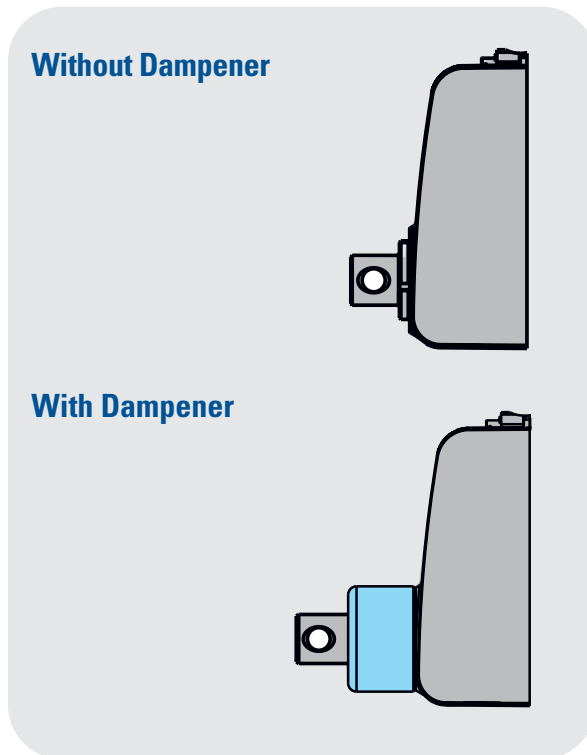

The dampening option is mounted between the rear adapter and the housing, and allows the actuator to absorb shock loads.



The Electrak XD shock dampening feature is ideal for applications such as loading buckets, which are commonly subjected to shock loads as they run into rocks, road cracks, cobble stones, manholes, curbs, speed bumps and potholes.



Applications – Material Handling

A significant part of modern production involves logistics – moving materials at the right time to the right place in the right amount. Ideally, production should incorporate little to no manual operation, which is why automated guided vehicles (AGVs) have become a common solution for factories and warehouses.



AGVs

AGVs come in many variations depending on what they carry and where they operate. Handling heavy loads in outdoor conditions is ideal for the Electrak® XD, and by using the CAN bus option, you can control, diagnose and read statistics in real time, allowing the process to be fine tuned on the fly.

Logistic Train Load Carriers

In many cases, AGVs are not moving any load themselves but instead acting as locomotives to move around a train of load carriers. The Electrak XD not only can handle the heavy loads but communicate with a central computer over a CAN bus network to control both the AGV route and carrier functions such as loading and unloading.

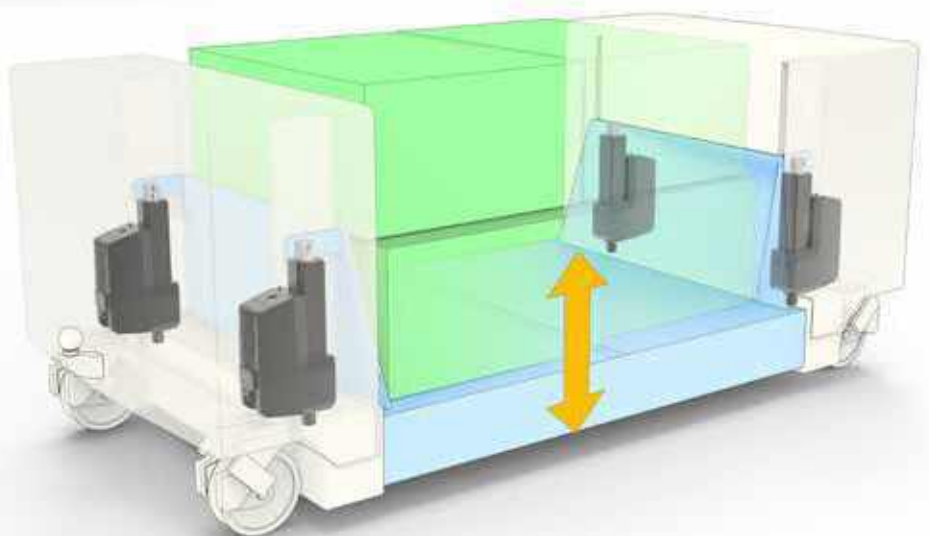

Applications – Transit Mobility

Getting travelers in and out of buses, airplanes or any other vehicle needs to be performed both swiftly and safely. Therefore, selecting the ideal components for these applications is paramount.



Boarding Stairs / Work Platforms

Connecting mobile boarding stairs safely to airplanes and ships, or positioning other types of work platforms requires strong, safe, reliable and lightweight solutions. The Electrak XD offers all of these benefits as well as reduced maintenance, lower energy costs and simpler installation compared to hydraulic systems.

Wheelchair Lifts and Ramps

It is vital to safely accommodate those traveling in wheelchairs as they enter and exit vehicles. Three key parts of a viable design solution are small footprint, low energy consumption and minimal to no maintenance. Electrak XD delivers all of these advantages as well as superior controllability and the ability to integrate the actuator with an existing CAN bus network.

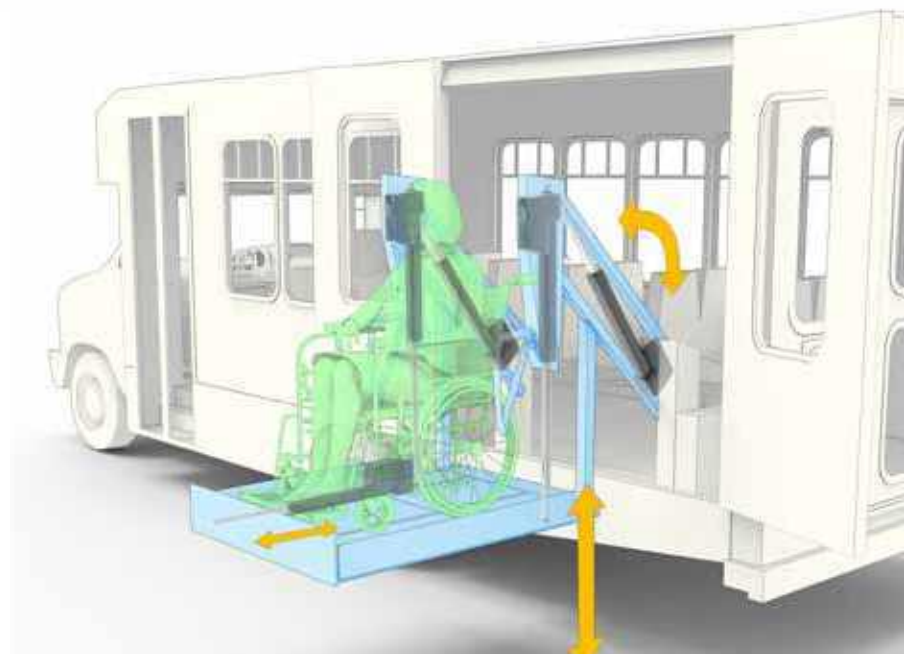



Applications – Agriculture and Forestry

Modern farming and logging are in the midst of a revolution in which operators are increasingly remote, and smart machines can check, adjust and report on water, fertilizer or seed used per every inch of a field to optimize yield. These tasks cannot be accomplished without a high degree of automation, incorporating precise, reliable and communicable equipment.

Combines, Tractors and Harvesters

Agricultural and forestry machines of today are far from the simple mechanical work horses they once were. These engineering marvels are high-tech, mobile production plants that move around somewhat autonomously, communicating with other equipment and micro-managing fields based on data. Key components to this modernization are smart, controllable and maintenance-free actuators such as the Electrak XD, which can be found in combines, tractors and other types of mobile off-highway equipment.

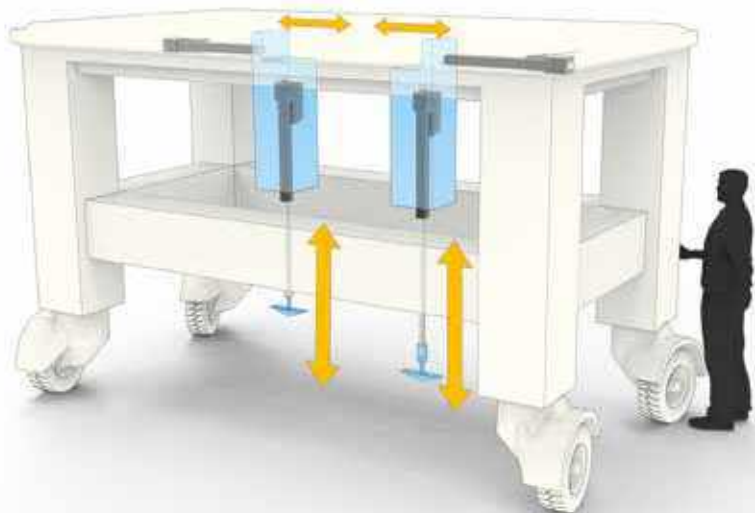
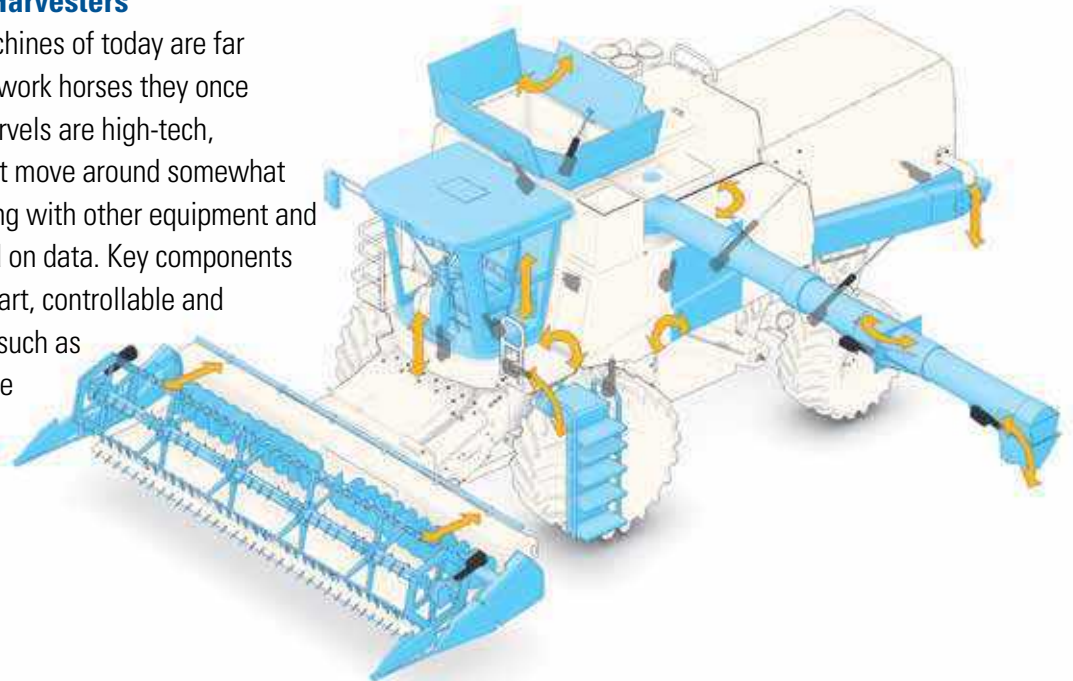

Automated Weed and Produce Pickers

A growing segment now being automated is the task of picking weeds and reporting the result back so that corrective actions to prevent further weed growth can be taken based on actual data. Smart electric actuators help in designing these machines and are rugged enough to work in the fields no matter rain, sun, snow or mud.

Applications – Factory Automation

The logistics within factory automation are ever-evolving, and smart, powerful electric linear actuators have opened up possibilities of replacing systems made of complex mechanical, pneumatic or hydraulic components with a more reliable, controllable, clean and energy-saving solution.

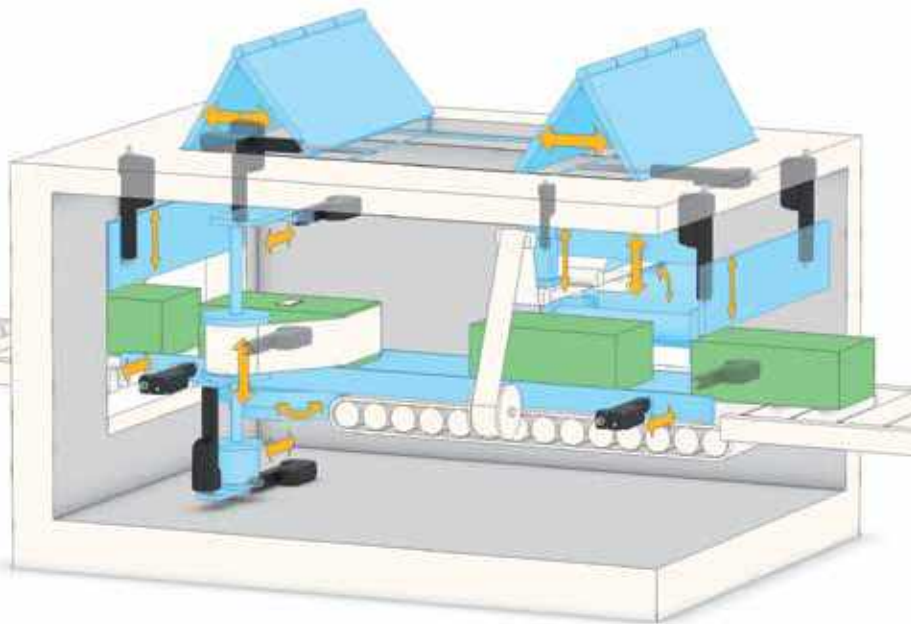

General Automation

Converting from hydraulic to electric actuators allows for cleaner machines that require less maintenance, while allowing for better controllability to increase throughput and quality. Replacing inefficient hydraulic pumps or, in some cases, the entire hydraulic infrastructure will also substantially reduce costs and save energy.

Assembly Lines and Work Stations

Smart electric actuators such as the Electrak XD are used in assembly lines and stations to lock, move or position tools or goods. These components allow CAN bus control to be used not only in the assembly line but also to communicate with AGVs, trucks, storage units and operators, streamlining the production process from start to finish.

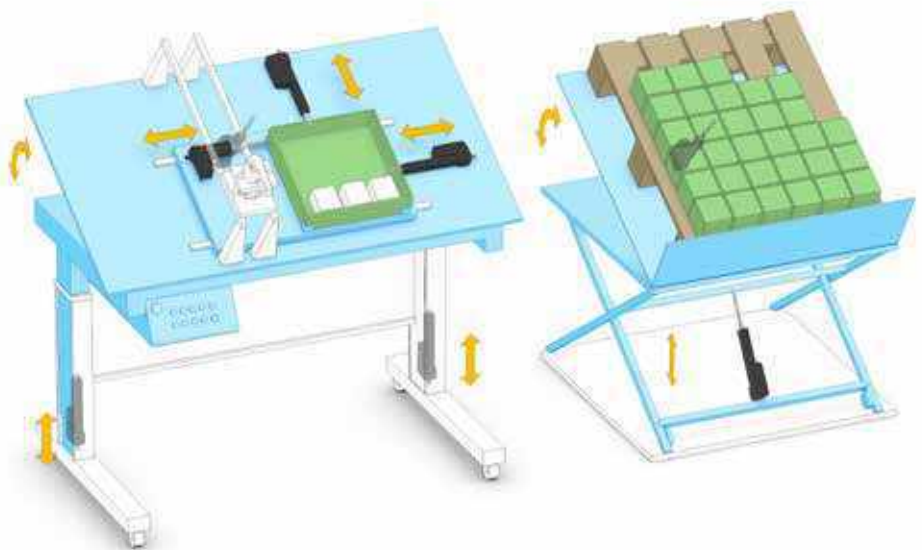



Technical Features



Electrak XD

- Constant speed irrespective of load
- Tough, strong and reliable
- Electronic Monitoring Package as standard
- Low-level signal motor switching as standard
- Speed control as standard
- Loads up to 25000 N (5620 lbf)
- Speeds up to 75 mm/s (2.95 in/s)
- Strokes up to 1200 mm
- Optional onboard controls
- Optional manual brake release and override
- Optional shock load dampening feature
- Optional force feedback

General Specifications

Screw type	ball
Nut type	load lock ball nut
Anti-rotation	yes
Dynamic braking	yes
Electrical connections Power Signal	integral screw terminals integrated housing connector
Electronic onboard controls	electronic monitoring package, low-level signal motor switching, and speed control
Compliance	CE, UKCA, RoHS, REACH (EU)

Safety Features

Static load holding brake	yes
End-of-stroke protection	yes
Overload protection	yes
Temperature monitoring	yes
Temperature compensation	yes
Voltage monitoring	yes
Current monitoring	yes

Electronic Monitoring Package Features

Current monitoring	Shuts down the actuator on overload and eliminates the need for the traditional mechanical clutch
Temperature and voltage monitoring	Protects the actuator by preventing motion when temperature and/or voltage are outside of normal ranges
Temperature compensation	Enables normal operation at lower temperatures without nuisance tripping
Software-controlled end-of-stroke limits	Ensure smooth, repeatable operation and protect the actuator
Dynamic braking	Enables quick, repeatable stops and eliminates coasting

Optional Features

Mechanical options	Shock load dampening
	Manual brake release/override
Control options (see page 28)	Digital position feedback
	End-of-stroke output
	Programmable limit switches
	SAE J1939 CAN bus
	CANopen®

Technical Specifications

Mechanical Specifications

Max. static load	[kN (lbf)]	see page 22
Max. dynamic load (Fx)	[kN (lbf)]	
XDxx-B055		5.5 (1236)
XDxx-B080		8.0 (1798)
XDxx-B160		16.0 (3597)
XDxx-B200		20.0 (4496)
XDxx-B250		25.0 (5620)
Speed ^{(1) (2)}	[mm/s (in/s)]	
XD24-B055		65 (2.56)
XD48-B055		75 (2.95)
XD24-B080		50 (1.97)
XD48-B080		50 (1.97)
XD24-B160		25 (0.98)
XD48-B160		25 (0.98)
XD24-B200		16 (0.63)
XD48-B200		20 (0.79)
XD24-B250		16 (0.63)
XD48-B250		16 (0.63)
Min. ordering stroke (S) length	[mm]	100
Max. ordering stroke (S) length	[mm]	
XDxx-B055(B080)		1200
XDxx-B160		1000
XDxx-B200		800
XDxx-B250		650
Ordering stroke length increments	[mm]	50
Operating temperature limits	[°C (F)]	-40 – 85 (-40 – 185)
Max. duty cycle @ 25 °C (77 °F)	[%]	
@ full load		50
@ other load		see page 23
End play, maximum	[mm (in)]	1.2 (0.047)
Restraining torque	[Nm (lbf-in)]	0
Weight of options	[kg (lbs)]	
Shock load dampening		1.16 (2.56)
Manual brake release and override		0.71 (1.56)
Protection class - static		IP67 / IP69K
Protection class - dynamic		IP66
Salt spray resistance	[h]	500

¹ Speed is constant and load independent from zero to max load.

² Do not use PWM voltage for speed control to avoid damaging the onboard electronics

Electrical Specifications

Available input voltages	[Vdc]	24, 48
Input voltage tolerance	[Vdc]	
XD24 (24 Vdc input voltage)		18 - 32
XD48 (48 Vdc input voltage)		36 - 60
Current draw @ min. / max. load	[A]	
XD24-Bxxx		6 / 28
XD48-Bxxx		3 / 14
Power supply ring terminal size		M6
Ring terminal hole center to insulation end distance, max. (Amax)	[mm]	34.5
Signal connector type*		
Female 12 pin Amphenol Ecomate		RTS014N12S03

* Connector manufacturers designation and part number.

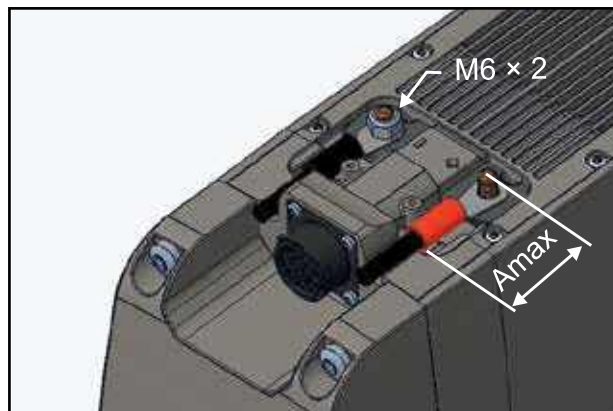

Connector for the control signals and inlets for the power supply wires.

Actuator Base Weight*

Mass	Ordering Stroke (S) [mm]																							
	100	150	200	250	300	350	400	450	500	550	600	650	700	750	800	850	900	950	1000	1050	1100	1150	1200	
[kg]	11.9	12.4	12.9	13.5	14.0	14.5	15.0	15.6	16.1	16.6	17.1	17.7	18.2	18.7	19.2	19.8	20.3	20.8	21.3	21.9	22.4	22.9	23.4	
[lbs]	26.1	27.3	28.5	29.7	30.8	32.0	33.1	34.3	35.4	36.6	37.8	39.0	40.1	41.3	42.4	43.6	44.7	45.9	47.0	48.2	49.4	50.6	51.7	

* For weight of options, see table above.



Ordering Key

Ordering Key

1	2	3	4	5	6	7	8	9
XD24	B055-	0200	LXX	-	M	M	S	N

1. Model and input voltage

XD24 = Electrak XD, 24 Vdc
XD48 = Electrak XD, 48 Vdc

2. Dynamic load capacity, speed and max. stroke length (S)

B055- = 5.5 kN @ 75 mm/s, 1200 mm
B080- = 8.0 kN @ 50 mm/s, 1200 mm
B160- = 16 kN @ 25mm/s, 1000 mm
B200- = 20 kN @ 20 mm/s, 800 mm
B250- = 25 kN @ 16 mm/s, 650 mm

3. Ordering stroke length (S) ^{(1) (2)}

0100 = 100 mm
0150 = 150 mm
0200 = 200 mm
0250 = 250 mm
0300 = 300 mm
0350 = 350 mm
0400 = 400 mm
0450 = 450 mm
0500 = 500 mm
0550 = 550 mm
0600 = 600 mm
0650 = 650 mm
0700 = 700 mm
0750 = 750 mm
0800 = 800 mm
0900 = 900 mm
0950 = 950 mm
1000 = 1000 mm
1050 = 1050 mm
1100 = 1100 mm
1150 = 1150 mm
1200 = 1200 mm

4. Electrak Modular Control System options ^{(3) (4)}

LXX = low-level signal motor switching + speed control + force feedback output
LXP = LXX + position feedback output
LLX = LXX + end-of-stroke indication outputs
LLP = LXX + position feedback + end- of-stroke indication outputs
PLS = LXX + programmable end-of-stroke limits
COO = CANopen[®] + closed loop speed control (includes diagnostics, position feedback, overload indication plus static and dynamic force feedback)
CNO = CAN bus SAE J1939 + closed loop speed control (includes diagnostics, position feedback, overload indication plus static and dynamic force feedback)

5. Manual Brake Release and Override Option

- = no manual brake release or override
R = manual brake release and override

6. Rear adapter option

M = 16 mm cross hole
N = 16 mm forked cross hole
H = M20 × 1.5 male thread
K = force feedback sensor with 16 mm cross hole ^{(4) (5)}

7. Front adapter option

M = 16 mm cross hole
N = 16 mm forked cross hole
H = M20 × 1.5 male thread
P = M20 × 1.5 female thread

8. Adapter orientation

S = standard
M = 90° turned

9. Mechanical shock load dampening ⁽⁵⁾

N = no dampening
M = dampening

(1) Max. possible stroke length depends on the dynamic load capacity, see position 2.

(2) Other stroke lengths available upon request. Please contact customer support.

(3) All Electrak XD are as standard equipped with the Electronic Monitoring Package.

(4) To use the force feedback function, the actuator must be equipped with rear adapter type K.

(5) To equip the actuator with the mechanical shock load dampening option, it also must be equipped with the rear adapter type M. This configuration will render the actuator incompatible with the force feedback option as it requires rear adapter type K.



Electrak HD and XD actuators compared to a ladder.



Performance Diagrams

Load vs. Current ⁽¹⁾

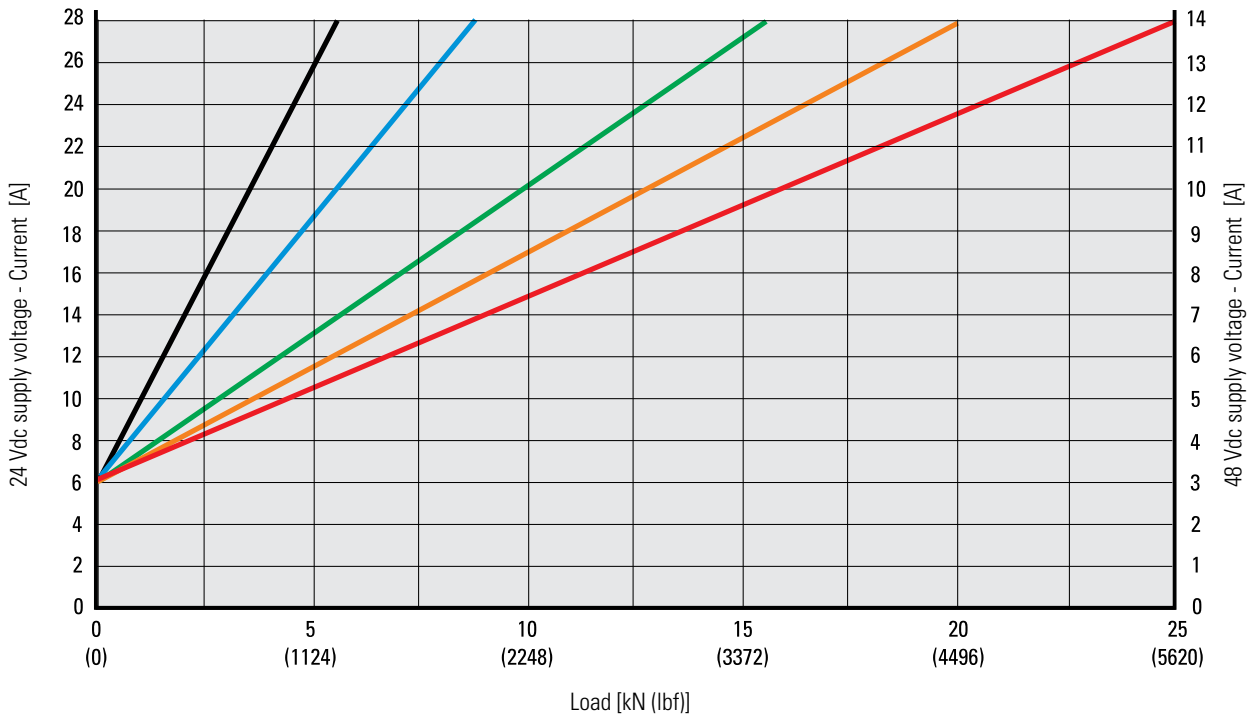

Dynamic Load vs. Stroke ⁽²⁾

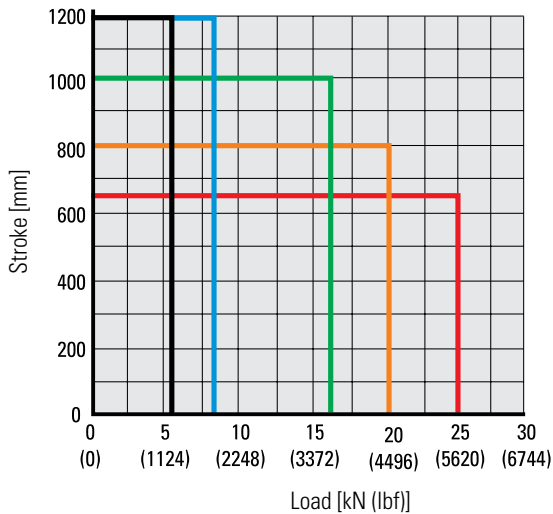

Static Compression Load vs. Stroke ⁽²⁾

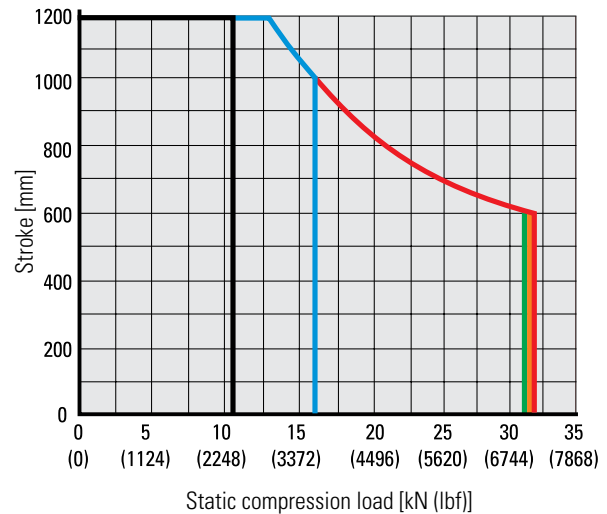

Actuator Dynamic Load Capacity Rating

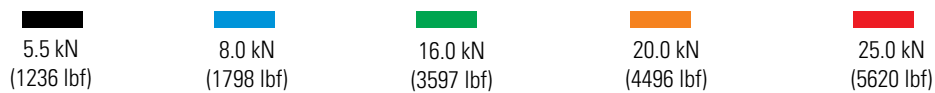

(1) Curves were generated at an ambient temperature of 25°C (77°F).

(2) Curves are for both tension and compression loads.

(3) Curves are for compression loads only except for 5.5 kN, which are also valid for tension loads. Contact customer support for non-compression type loads.

Performance Diagrams

Load vs. Speed

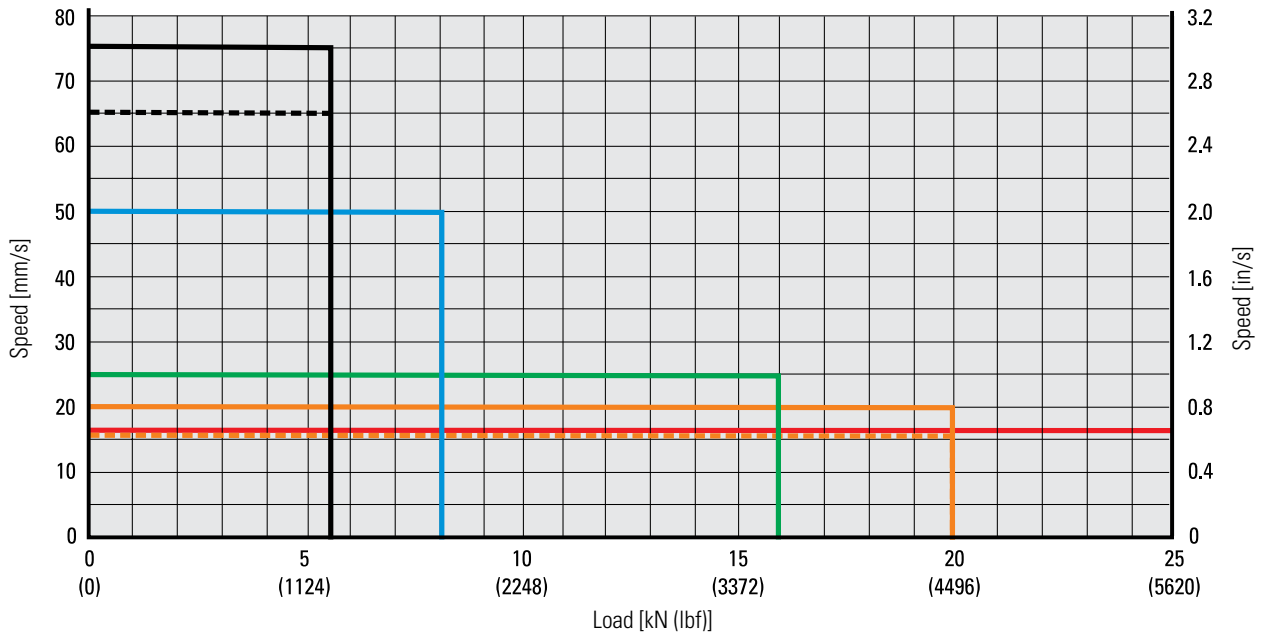

Actuator Dynamic Load Capacity Rating and Supply Voltage

24 Vdc	48 Vdc	24 / 48 Vdc	24 / 48 Vdc	24 Vdc	48 Vdc	24 / 48 Vdc
5.5 kN (1236 lbf)	5.5 kN (1236 lbf)	8.0 kN (1798 lbf)	16.0 kN (3597 lbf)	20.0 kN (4496 lbf)	20.0 kN (4496 lbf)	25.0 kN (5620 lbf)

Estimated Life vs. Load

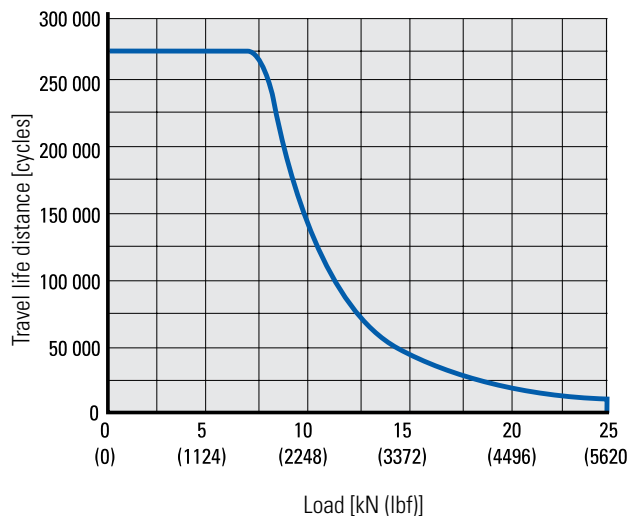

Duty Cycle

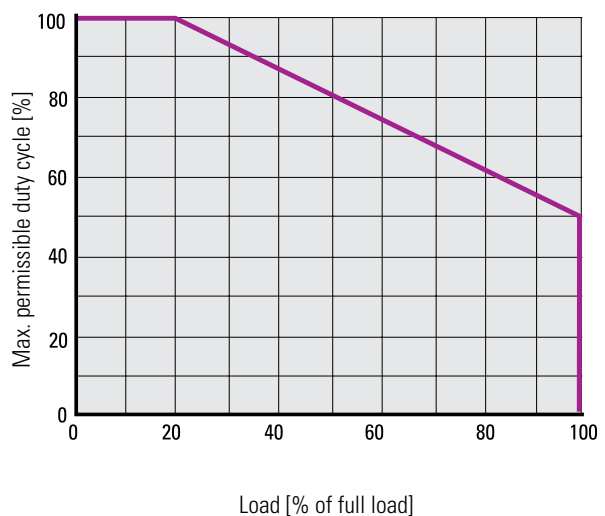

Estimation for a fully loaded unit with 300 mm stroke moving a resistive load in both directions at an ambient temperature of 20°C (68°F) and a duty cycle of 40%. A more accurate travel life calculation requires additional application information. Contact customer support for assistance.



Dimensions

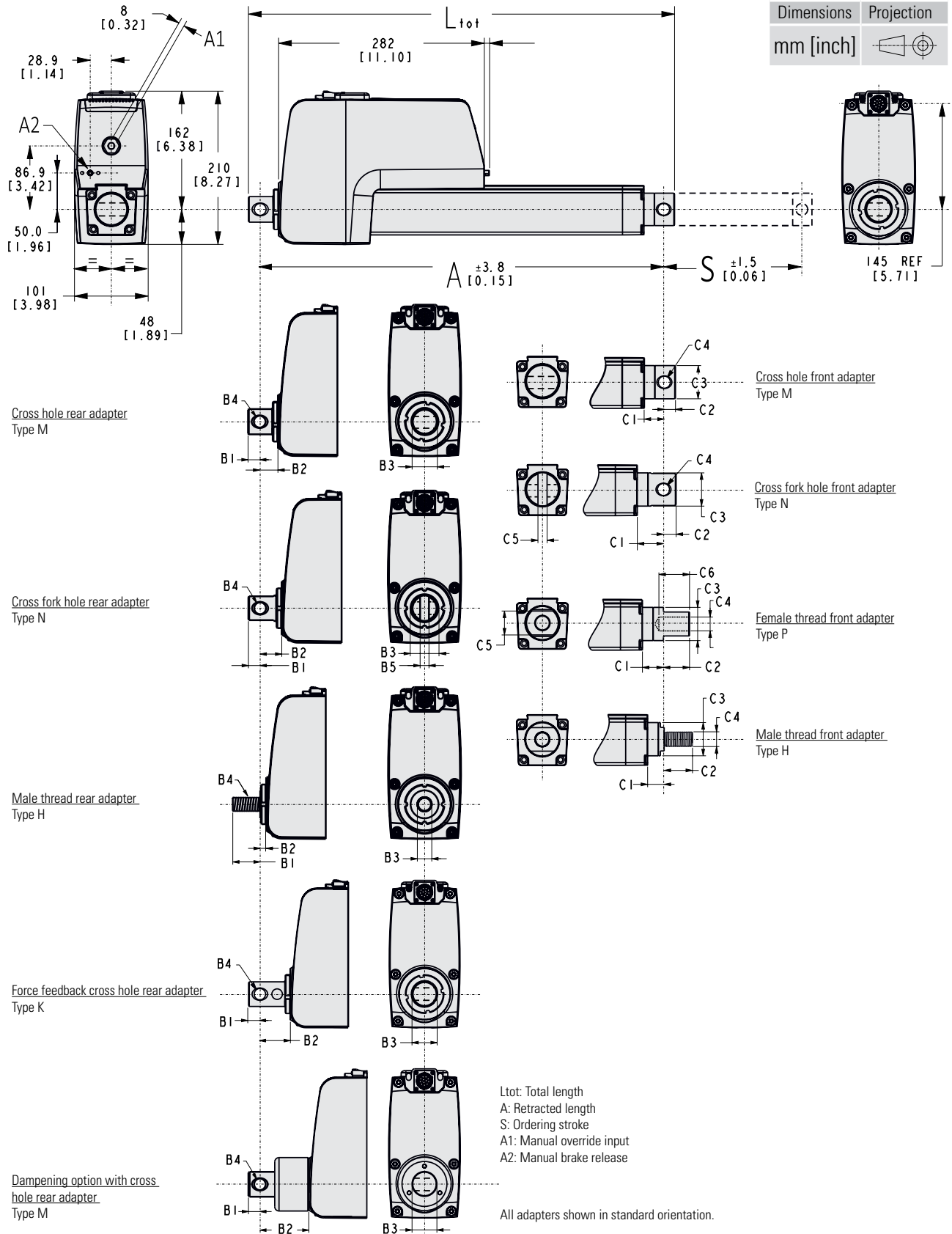

Dimensions

Stroke, Retracted Length and Total Length Relationships

Ordering stroke (S)	[mm]	100 - 1200 mm in 50 mm increments
Retracted Length (A)	[mm (in)]	$S + 200.8 (7.91) + B2 + C1$
Total Length (Ltot)		$A + B1 + C2$

Rear and Front Adapter Dimensions [mm (in)]

	Rear Adapter Types				
	M	N	H	K	M + dampening option
B1	16.1 (0.63)	16.1 (0.63)	38.0 (1.50)	16.1 (0.63)	16.1 (0.63)
B2	25.3 (1.00)	29.9 (1.18)	8.2 (0.32)	43.3 (1.70)	68.9 (2.71)
B3	35.0 (1.38)	35.0 (1.38)	M20 × 1.5	35.0 (1.38)	35.0 (1.38)
B4	16.2 (0.64)	16.2 (0.64)	M20 × 1.5	16.2 (0.64)	16.2 (0.64)
B5	-	12.2 (0.48)	-	--	
	Front Adapter Types				
	M	N	P	H	
C1	27.1 (1.07)	35.1 (1.38)	28.1 (1.11)	22.1 (0.87)	
C2	14.9 (0.59)	16.9 (0.67)	35.0 (1.38)	38.0 (1.50)	
C3	44.5 (1.75)	44.5 (1.75)	44.5 (1.75)	44.5 (1.75)	
C4	16.2 (0.64)	16.2 (0.64)	M20 × 1.5	M20 × 1.5	
C5	-	12.2 (0.48)	32.0 (1.26)	-	
C6	-	-	35.0 (1.38)	-	



Mechanical Options

Manual Brake Release and Override Type R		
Weight of option	[kg (lbs)]	0.71 (1.56)
Manual brake release specifications		
Brake release lever pull operation force for full brake release	[N (lbf)]	40 (15)
Brake release lever operation pull distance for full brake release	[mm (in)]	10 (0.4)
Brake lever inside hole thread (a)		10-32"
Brake lever bracket mounting holes (b)		M5
Manual override specifications		
Required override input torque @ full load	[Nm (lbf-in)]	6 (53.1)
Max. permissible override input torque	[Nm (lbf-in)]	9 (79.7)
Max. override input speed	[rpm]	500
Linear movement / override input turn	[mm]	
XDxx-B055		1.3
XDxx-B080		1.3
XDxx-B160		0.5
XDxx-B200		0.31
XDxx-B250		0.31
Rotational direction of the input		
clockwise seen from front		tube extends
counter clockwise seen from front		tube retracts
Maximum run time	[min]	1
Cool-down time between operations	[min]	5
Manual override input hex key sizes	[mm]	
cover plug (c) and		8
override input shaft		8

Electrak[®] XD can be equipped with the manual brake release and override option, which allows the extension tube to be released and/or manually cranked back and forth.

Manual Brake Release

When engaged, the manual brake release will release the extension tube from the brake so that it can move freely. In case of a helping load, the operator must ensure releasing the extension tube will not create a hazardous situation since the tube will immediately move in the direction the force is acting.

It is also critical when releasing a helping load that the actuator is connected to a power source or any other device that can take the regenerated energy from the motor when it is acting as a generator. In order to operate the brake release lever, (a) must be pulled. The mounting holes (b) are provided so that a bracket can be easily installed as a support for a cable assembly used for remote lever operation. To release the brake completely, the lever needs to be pulled in 10 mm (0.4 in) with a force of 40 N (15 lbf). Shorter distance and lower force will open the brake partially and allow for a slower, more controlled movement.

Manual Override Input

Access is granted to the manual override shaft input head (c) by removing the cover plug. Using a hex bit as a crank allows the extension tube to be moved back and forth. Using the manual override does not require the manual brake release to be operated as the override input will disengage the brake by itself while being used. A power tool can be used to operate the manual override as long as it starts and stops smoothly and the input speed doesn't exceed 500 rpm. The override has a maximum run time of one minute and requires a five-minute cool-down between events.

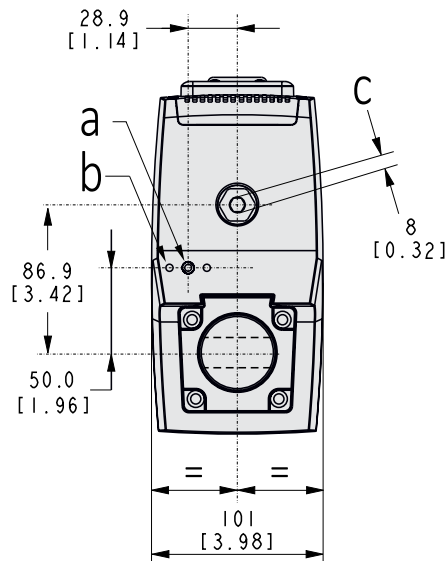

Mechanical Options

Shock Load Dampening Type M

Max. shock load force	[kN (lbf)]	48 (10791)
Max. dampening distance (max. Ldd)	[mm (in)]	± 2.7 (0.11)
Weight of option	[kg (lbs)]	1.16 (2.56)
Operating temperature limits	[°C (F)]	-40 – 85 (-40 – 185)
Life expectancy		as the actuator
Maintenance		not required

Electrak XD can be equipped with the shock load dampening option, which will absorb shock loads and thus increase the life of the actuator. The dampener consists of a rear adapter combined with a dampener unit that replaces the standard adapter, adding to the total length and weight of the actuator.

Shock Load Dampener

When an extension tube equipped with the shock load dampening option is subjected to a shock load, the dampener will be extended or compressed depending on the direction of the shock load force before returning to its original position. The distance is mainly related to the shock load force (as seen in the diagram), but the load, temperature, shock load speed and mounting position will also affect the distance.

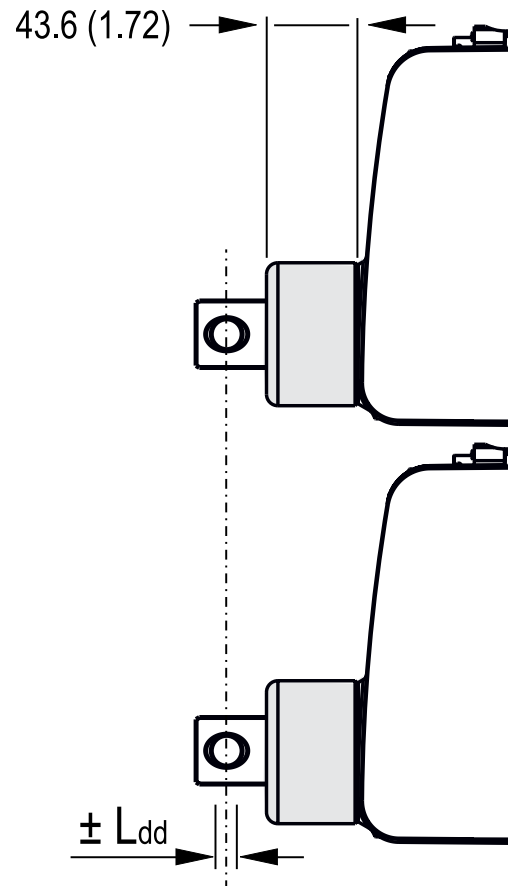

Dampening Distance vs. Shock Load

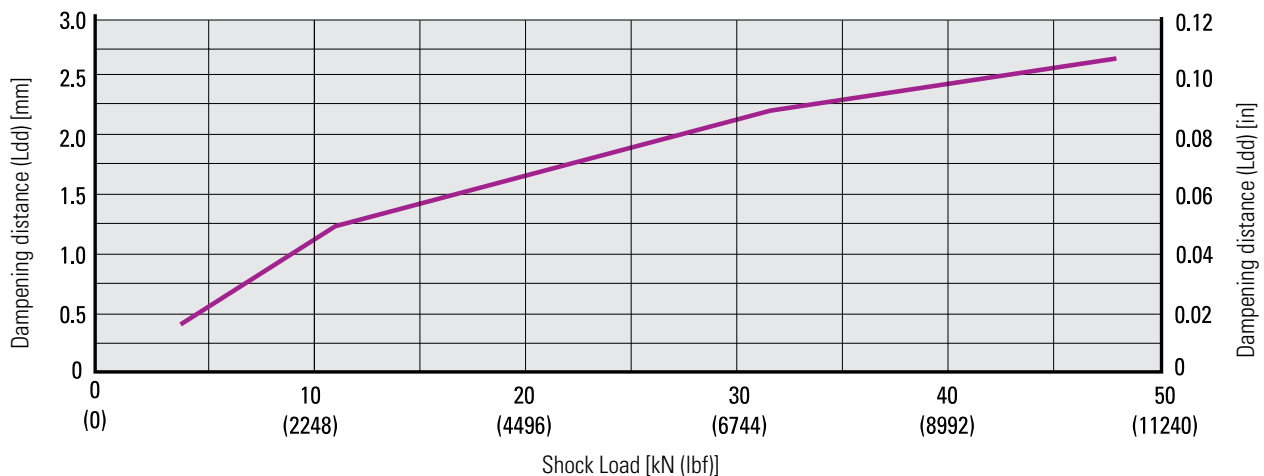



Control Standard Features

All Electrak® XD controls, except for the CAN bus options (CNO and COO), have as a minimum the basic Electrak Monitoring Package features and low-level switching, speed control and optional force feedback capabilities as described below. This minimum configuration is called control option LXX.

Electrak Monitoring Package Features

The monitoring package includes:

- Current monitoring - shuts down the actuator on overload.
- Temperature and voltage monitoring - protects the actuator by preventing motion when temperature and/or voltage are outside of normal ranges.
- Temperature compensation - enables normal operation at low temperatures.
- Software controlled end-of-stroke limits - protect the actuator and ensure smooth stops.
- Dynamic braking - produces quick, repeatable stops with no coasting.

Low-level Switching

With low-level switching, the customer-supplied switches/relays that are connected to the extend and retract inputs only need to handle low-level signals and not the voltage and current of the motor.

Speed Control

If the speed control input is not used when the extend and retract inputs are active, the actuator will move at its full speed as long as the max. load is not exceeded. If a 0 - 5 Vdc signal is connected to the speed control input, the speed of the actuator can be regulated between 20 - 100% of its full speed where 0 - 0.5 V corresponds to full speed and 1 - 5 V corresponds to 20% of full speed up to full speed.

Speed vs. Speed Control Input Voltage

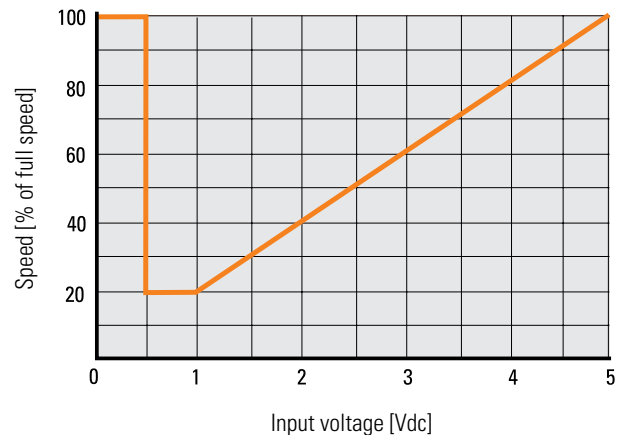

Force Feedback Output

In order to use the force feedback output, the actuator must be equipped with an integral force feedback sensor (rear adapter type K). The force output is a 0 - 5 Vdc signal where 2.5 V is zero force, 0.5 V is 25 kN compression force and 4.5 V is 25 kN tension force. Between 0.5 - 4.5 V, the output changes 1 mV per 12.5 N in change of force.

Force vs. Force Feedback Output Voltage

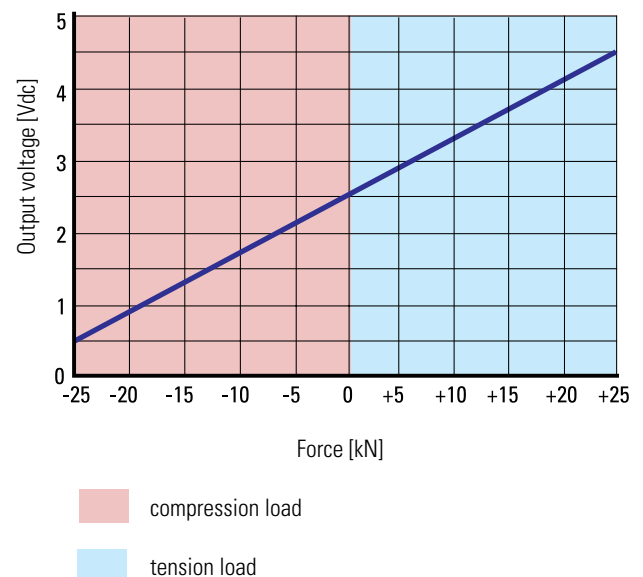

Control Options

All Control Options		
Actuator supply voltage limits	[Vdc]	
XD24		18 - 32
XD48		36 - 60
Current draw @ min. / max. load	[A]	
XD24-Bxxx		6 / 28
XD48-Bxxx		3 / 14
End-of-stroke protection		yes
Overload protection		yes
Temperature monitoring		yes
Temperature compensation		yes
Voltage monitoring		yes
Current monitoring		yes
Speed control possible by supply voltage PWM		no

Fuse

Use a slow blow fuse on the supply voltage input wiring to protect the actuator and the wiring. Size it in accordance with local regulations and the current draw for the application in question.

Voltage drop

Long supply wires may need an increased cross section in order to prevent the supply voltage to drop to levels below the supply voltage limit of the actuator. Calculations to determine the necessary cross section should take local regulations, application specifics and the actuator supply voltage limits into account.

Speed control by pulse width modulation (PWM)

The actuator speed can't be changed by PWM control of the supply voltage as the actuator may be harmed by this action. Speed of the actuator can only be controlled by using the speed control input or the CAN bus speed control commands.

Regeneration current with helping load

When encountering a helping load, the motor acts as a generator and it is important to ensure that the power supply used can handle the power generated back by the motor.

Control Option Type LXX

Extend / retract input voltage	[Vdc]	9 - 64
Extend / retract input current	[mA]	0.35 - 2.75
Speed control input voltage range	[Vdc]	0.5 - 5
Speed control range of full speed	[%]	20 - 100
Force feedback output voltage range	[Vdc]	0.5 - 4.5
Force feedback linearity	[%]	± 5
Force feedback resolution	[N/mV]	12.5

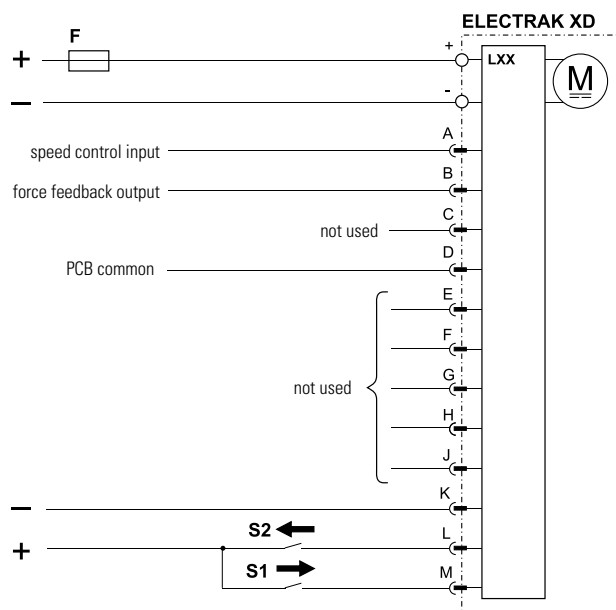
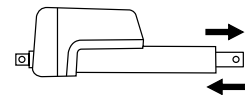

- + / - Supply voltage positive / negative
- F Fuse
- S1 Extend switch/relay
- S2 Retract switch/relay

Control option LXX includes all of the basic Electrak Monitoring Package features plus low-level switching, speed control and force feedback capabilities.



Control Options

Control Option Type LLX

Extend / retract input voltage	[Vdc]	9 - 64
Extend / retract input current	[mA]	0.35 - 2.75
Speed control input voltage range	[Vdc]	0.5 - 5
Speed control range of full speed	[%]	20 - 100
Force feedback output voltage range	[Vdc]	0.5 - 4.5
Force feedback linearity	[%]	± 5
Force feedback resolution	[N/mV]	12.5
End-of-stroke output contact type		potential free
Max. end-of-stroke output voltage	[Vdc/ac]	30/120
Max. end-of-stroke output current	[mA]	100

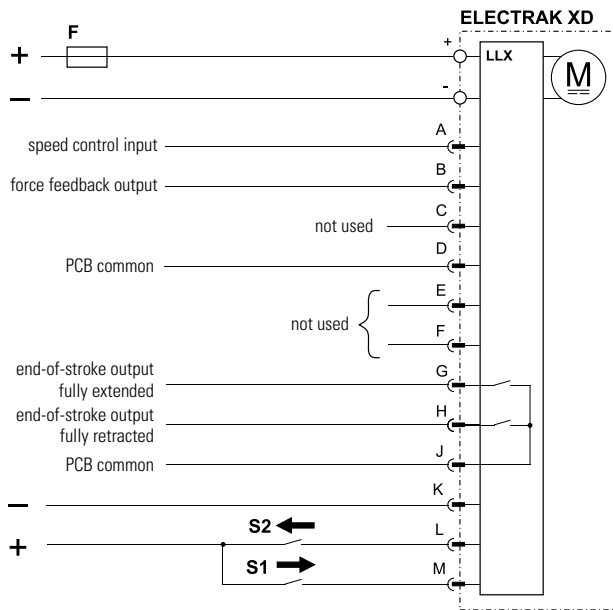
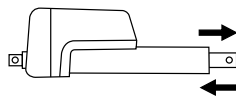

- + / - Supply voltage positive / negative
- F Fuse
- S1 Extend switch/relay
- S2 Retract switch/relay

Control option LLX works as option LXX but also includes two end-of-stroke outputs that indicate when the extension tube is in its fully extended or retracted position.

Control Option Type LXP

Extend / retract input voltage	[Vdc]	9 - 64
Extend / retract input current	[mA]	0.35 - 2.75
Speed control input voltage range	[Vdc]	0.5 - 5
Speed control range of full speed	[%]	20 - 100
Force feedback output voltage range	[Vdc]	0.5 - 4.5
Force feedback linearity	[%]	± 5
Force feedback resolution	[N/mV]	12.5
Position feedback output voltage	[Vdc]	0.5 - 4.5
Position feedback linearity	[%]	± 0.25
Position feedback resolution	[mm/V]	ordering stroke length (S) [mm] / 4

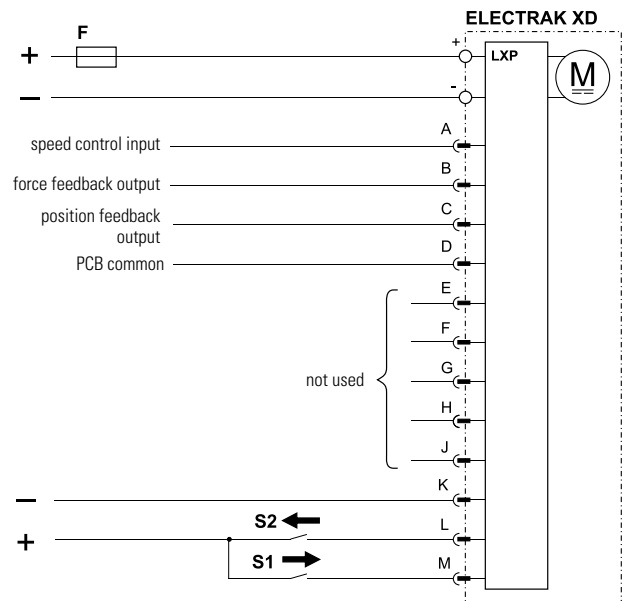
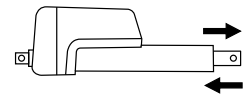

- + / - Supply voltage positive / negative
- F Fuse
- S1 Extend switch/relay
- S2 Retract switch/relay

Control option LXP works as option LXX but also includes an analog position output that will provide feedback on the extension tube position.

Control Options

Control Option Type LLP		
Extend / retract input voltage	[Vdc]	9 - 64
Extend / retract input current	[mA]	0.35 - 2.75
Speed control input voltage range	[Vdc]	0.5 - 5
Speed control range of full speed	[%]	20 - 100
Force feedback output voltage range	[Vdc]	0.5 - 4.5
Force feedback linearity	[%]	± 5
Force feedback resolution	[N/mV]	12.5
End-of-stroke output contact type		potential free
Max. end-of-stroke output voltage	[Vdc/ac]	30/120
Max. end-of-stroke output current	[mA]	100
Position feedback output voltage	[Vdc]	0.5 - 4.5
Position feedback linearity	[%]	± 0.25
Position feedback resolution	[mm/V]	ordering stroke length (S) [mm] / 4

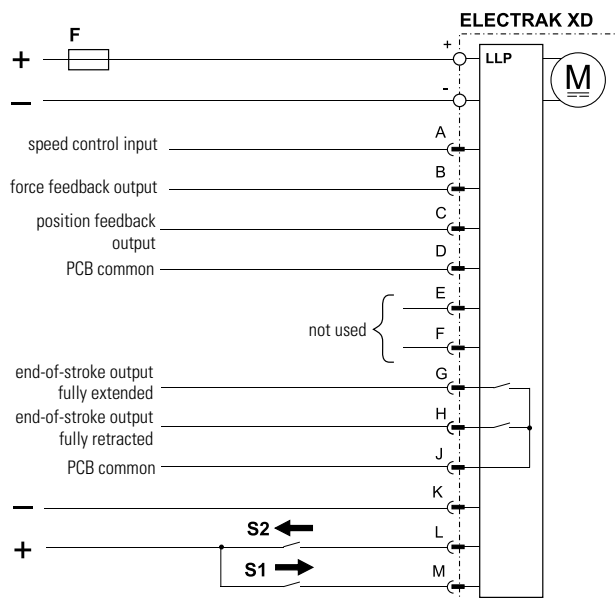
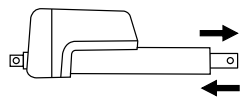

- + / - Supply voltage positive / negative
- F Fuse
- S1 Extend switch/relay
- S2 Retract switch/relay

Control option LLP works as option LXP but also includes two end-of-stroke outputs that indicate when the extension tube is in its fully extended or retracted position.

Control Option Type PLS		
Extend / retract input voltage	[Vdc]	9 - 64
Extend / retract input current	[mA]	0.35 - 2.75
Speed control input voltage range	[Vdc]	0.5 - 5
Speed control range of full speed	[%]	20 - 100
Force feedback output voltage range	[Vdc]	0.5 - 4.5
Force feedback linearity	[%]	± 5
Force feedback resolution	[N/mV]	12.5

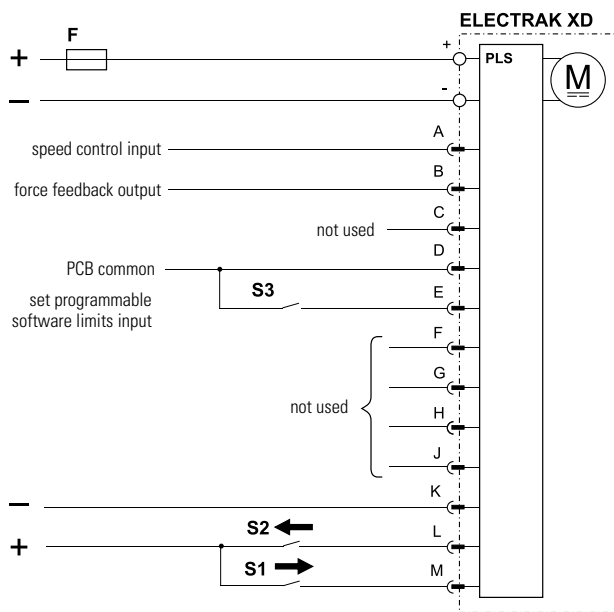
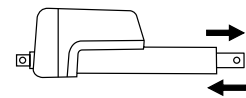

- + / - Supply voltage positive / negative
- F Fuse
- S1 Extend switch/relay
- S2 Retract switch/relay
- S3 Set programmable software limits switch

Control option PLS works as option LXX but also includes programmable software extend and retract limits.



Control Options

Control Option Type CNO and COO

Command data includes:

- position
- speed
- current

Feedback data includes:

- position
- speed
- current
- force (the actuator must also be equipped with the force feedback rear adapter type K)
- other diagnostic information

Extend / retract input voltage	[Vdc]	9 - 64
--------------------------------	-------	--------

Extend / retract input current	[mA]	0.35 - 2.75
--------------------------------	------	-------------

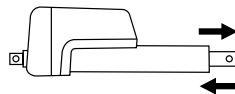

Control option CNO includes a SAE J1939 CAN bus control interface, COO includes a CANopen® control interface that controls and monitors the actuator. Movement commands are sent via CAN messages on the CAN low and CAN high inputs. Inputs on pins G, H and J can be used as a binary coded decimal (BCD) adder to change the default address of the actuator. This option can be used when multiple CAN bus actuators are located on a single bus. The actuator can be manually forced to extend or retract by using the inputs on pin L and M. When the manual control inputs are used, CAN bus control messages are ignored, but the unit will still provide CAN bus feedback messages. When the inputs are left floating, CAN bus functionality for control messages is restored. When using the address inputs and/or the manual extend and retract switches, pin K must be connected to supply voltage negative.

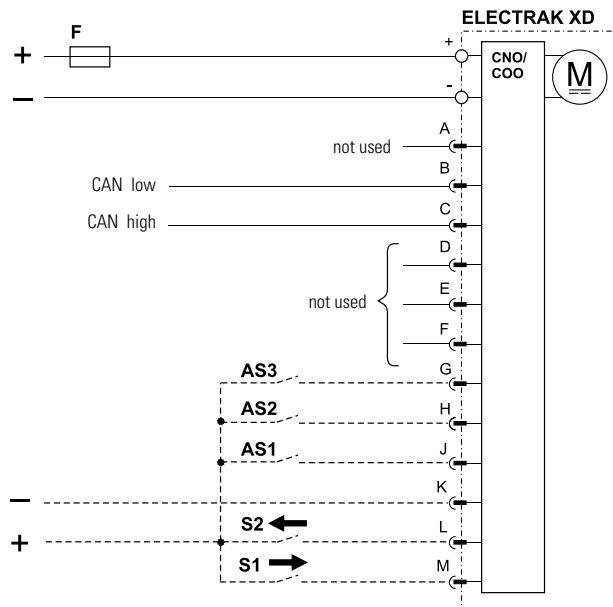

+ / - Supply voltage positive / negative

F Fuse

S1 Manual extend switch/relay (optional)

S2 Manual retract switch/relay (optional)

AS1 Address selection switch for binary position 1

AS2 Address selection switch for binary position 2

AS3 Address selection switch for binary position 3

Accessories

Signal Cable and Connector Harness		
Length without connector	[mm (in)]	1500 (59)
Lead cross section/size	[mm ² (AWG)]	0.5 (20)
Pin to lead color		A - pink B - brown C - blue D - black E - orange/black F - yellow/black G - white H - red J - green K - grey L - orange M - violet
Part number		954-9476

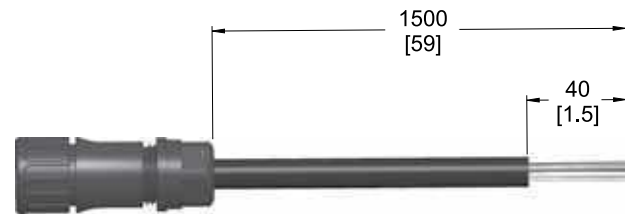



Customization

Can't find what you need for your application's design requirements? Experienced Thomson engineers are ready to work alongside you to find your optimal custom solution. From a small modification to a unique, white paper design that perfectly matches your needs, we are your trusted partner.

Thomson has been providing custom actuator solutions for decades. We have an extensive library of modifications that we can apply, ranging from surface treatments to custom strokes or supply voltage.



Thomson offers a wide range of proven standard electric actuators to use as a basis for custom designs.

Ingress Protection

Custom sealings, gaskets, bellows and other design solutions can be provided to bolster protection from the elements.

Sensors and Switches

Pre-mounting both internal and external sensors at the factory can save you significant time.

Controls or Software

Integrating custom controls and/or software instead of changing the physical size/properties of the actuator is often an easier means to enhance its intelligence.

Electrical Connections

Special cables, connectors or custom harnesses can be added to match your application requirements.

Adapters

Both front and rear adapters can be customized to fit your application to help the actuator fit into a given mounting position.

Stroke

Stroke length is a common and easily done customization.

Surface Treatment

Thomson can provide a custom color, coating or other special surface treatment to the Electrak XD.

Voltage

Custom supply voltages is a common actuator modification.

Speed or Force

Custom gears can alter the speed and/or force of the actuator to suit the application.



Frequently Asked Questions

Is Electrak XD maintenance free?

Yes. Electrak XD never requires lubrication, maintenance or adjustment for wear.

Is it possible for a load to back-drive the extension tube?

No. Electrak XD has a load holding brake.

What is the difference between a tension and a compression load?

A tension load tries to stretch the actuator, while a compression load tries to compress it. With bi-directional loads, the end play of the actuator extension tube may need to be taken into consideration when using the actuator for positioning tasks.

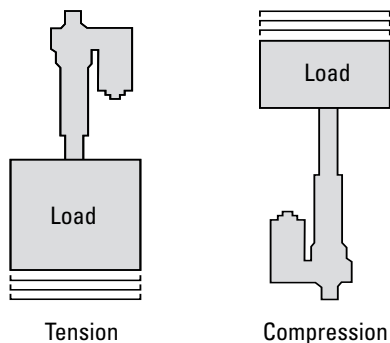

Can Electrak XD be side loaded?

No. A proper design of the application should eliminate any side loads.

What is the range of input voltage an Electrak XD can operate with?

The nominal input voltage is 24 Vdc or 48 Vdc depending on model. A 24 Vdc model will however accept 18 – 32 Vdc while the range for 48 Vdc model is 36 – 60 Vdc. Outside of these limits, the Electronic Monitoring Package will prevent the actuator from operating.

Which power supply should I use with the Electrak XD?

The Electrak XD is equipped with a brushless motor. When running the actuator with a helping load, it will generate current. Thomson recommends using a battery as a power supply. If a transformer is used, it must be able to handle current coming from the actuator.

What is the inrush current?

The inrush current is a short current peak that appears at the start of an actuator as the motor tries to get the load moving. Typically, the inrush current will last between 75 – 150 milliseconds and can be up to three times higher (on a low-level switched actuator - 1.5 times higher) than the current for the actuator and load. Batteries have no problem delivering the inrush current, but if using an AC-powered power supply, it is important to size it to handle the inrush current.

What special mounting considerations does the Electrak XD require?

There is no restraining torque that needs to be considered as Electrak XD is internally restrained. However, the actuator must be mounted so that there are no side loads acting on the extension tube. It is also important that the manual override input is accessible after the actuator is mounted and that connectors and cables are placed so that they are not damaged during operation.

What is the maximum travel speed?

The speed of an Electrak XD actuator is constant (and therefore always at its “maximum”) irrespective of the load as long as it is within the rated load range. If the actuator is overloaded, it will stop.