

## Next Generation RIM Tach® Product Line

Mill-Duty Digital Tachometers

### Mill-duty magnetic encoders that keep you ahead of the curve.

The NorthStar (Lakeshore) RIM Tach product line was originally introduced over 20 years ago to provide the highest performance feedback solution for the most demanding motor and drive control systems in the industry. Now NorthStar is leading the way again with the Next Generation RIM Tach product line, offering an unparalleled level of reliability, ease of installation, and performance.

The Next Generation RIM Tach is available in bearingless modular mounting configurations for NEMA 8.5" or NEMA 12.5" C-faces for AC or DC motor mounting or a 56C C-face/foot mount configuration for close coupled or belted applications. The NorthStar NexGen RIM Tach is a drop-in replacement for previous NorthStar/Lakeshore RIM Tach models and Avtron™ models.

#### Proven mill-duty design features you expect:

- Ductile "fully coated" Cast Iron Housings
- Stainless Steel Replaceable Sensor Modules
- Fully Encapsulated Electronics
- Best In Class Pulse Wheel Options

#### Redesigned for unmatched reliability and performance:

- The Most Reliable Magnetic Technology Available Today
- Largest Non-Contact Sensing Gap Available On The Market
- Higher Resolutions to 2400 PPR
- Active LED Indicator With Diagnostics



RIM Tach 8500  
NexGen (RT8)



RIM Tach 1250  
NexGen (RT1)

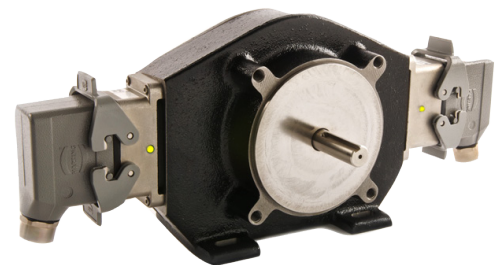

RIM Tach 6200  
NexGen (RT6)

# NorthStar™

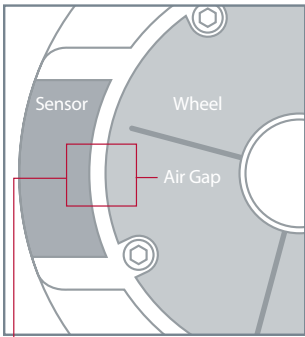

**NorthStar RIM Tach 8500®**  
NexGen's curved sensor head features the largest gap on the market

Industry leading 0.070" Air Gap



## Get to Know the Features & Benefits

PRODUCT FEATURES	WHY THIS BENEFITS YOU
Largest non-contact sensing gap (0.070" nominal) and axial tolerance (up to +/- 0.250") available on the market.	Quick and easy installation. No precision tools, shims or measurements required. More forgiving in tough applications where brakes or other dynamic shaft deflections could previously cause wheel to sensor strikes.
Higher resolutions to 2400PPR with strong clear signal output.	More reliable signal for demanding applications and higher performance drives.
On-board diagnostics with active LED for diagnostics and troubleshooting	Visual indication for troubleshooting during installation and operation, preventing unscheduled downtime.
NEW pulse wheel shaft lock design.	Industry leading wheel design positively locks to the shaft without damaging the shaft. No setscrews or cams.
Protective magnetic wheel edge guard.	Protects magnetic surface on the wheel from rough handling
High current 5-24VDC line driver with active line suppression and protection from ESD, reverse polarity, short circuits, and powered shorts.	Allows for trouble-free operation with long cable runs. Universal voltage range for system flexibility. Protection from electrical connection issues.
Wide temperature range of -40° to +100° C	Reliable operation in extreme conditions
NexGen RIM Tach sensor module and wheel are reverse compatible with previous generation RIM Tach series housings and accessories	Take advantage of the benefits of today's new technology and upgrade existing NorthStar RIM Tach 8500 and 1250 encoders by simply replacing the sensor module and wheel. Save money by reusing existing housings and accessories.

**NorthStar** - Pioneers of proven magnetic digital tachometers, remains committed to developing new and reliable products, delivering quality, and outstanding service to our customers.